



Community Planning & Permitting

Courthouse Annex • 2045 13th Street • Boulder, Colorado 80302
Mailing Address: P.O. Box 471 • Boulder, Colorado 80306
303-441-3930 • www.BoulderCounty.gov

BOULDER COUNTY BOARD OF ADJUSTMENT PUBLIC HEARING

August 6, 2025 at 4:00 p.m.

Boulder County Courthouse, 3rd Floor,
1325 Pearl Street, Boulder
Virtual and in-person

STAFF RECOMMENDATION RE: DOCKET VAR-25-0003: PSCO SETBACK VARIANCE

DATE PUBLISHED: July 30, 2025

STAFF PLANNER: Pete L'Orange, Senior Planner

Docket VAR-25-0003: PSCo Setback Variance

Proposal: Variance request to reduce the 35-foot front setback to 7 feet and the 110-foot supplemental setback to 28 feet for the construction of a new utility structure.

Location: 11253 Dillion Road, an approximately 0.122-acre parcel, located at the northeast corner of Dillion Road and US Highway 287, in Section 14, Township 1S, Range 69W.

Zoning: Agricultural (A) Zoning District

Owner/Applicants: Xcel Energy

Agent: Christian Kopec

PACKET CONTENTS:

Item	Pages
Staff Recommendation	1 – 8
Application Materials (Attachment A)	A1 – A19
Referral Responses (Attachment B)	B1 – B15

SUMMARY AND RECOMMENDATION:

The applicants request a reduction in the required 35-foot front setback to 7 feet and the 110-foot supplemental setback to 28 feet to allow for the construction of a new utility structure. Staff recommend that this variance request be approved because the applicable review criteria in Article 4-1202.B.2 of the Boulder County Land Use Code (the Code) can be met.

DISCUSSION:

The subject parcel is located at the northeast corner of Dillion Road and US Highway 287 (see Figure 1 below). It is approximately 0.122 acres (5,309 square feet) in size and currently has an approximately 50-square-foot utility structure within a fenced-in area.

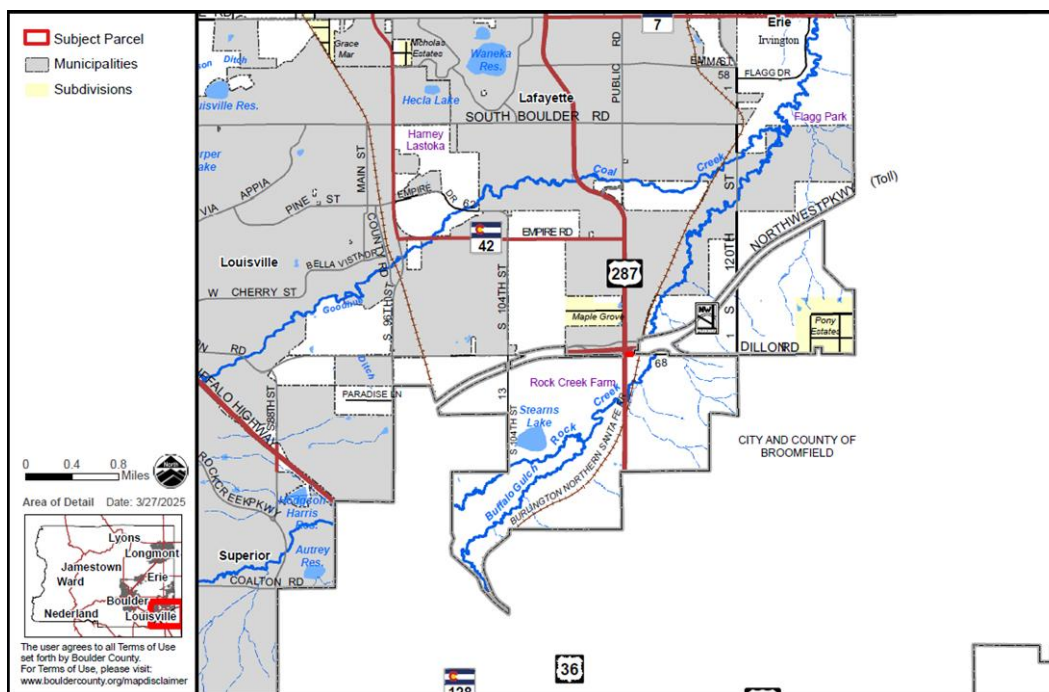

Figure 1: Vicinity Map showing location of the subject parcel.¹

The Boulder County Comprehensive Plan indicates that there are Agricultural Lands of National and Local importance in the vicinity of the subject parcel, but none on or immediately adjacent the subject parcel itself (see Figure 2 below). There are Viewshed Protection scores along Dillion Road, with a ratings ranging from 0.51 to 1.61 out of 5, and US 287, with a rating of 0.98 out of 5.

¹ Note: Due to a mapping error, most of the parcel maps show the subject parcel located in the middle of Dillion Road; based on the parcel deeds, however, it is actually located immediately north of the roadway.



Figure 2: Comprehensive Plan map.

Finally, the subject parcel is located within the 500-year floodplain (see Figure 3 below).



Figure 3: Floodplain map, with identified 500-Year Floodplain areas indicated in orange.

The subject parcel is located within the Agricultural zoning district; the parcels to the south and southeast are a mix of Commercial, General Industrial, and Transitional zoning districts; and the parcels to the north and northwest are located within the City of Lafayette (see Figure 4 below). In addition to the standard zoning district setbacks, there are 110-foot supplemental setbacks along both Dillon Road and US 287. The 110-foot supplemental setback on Dillon Road covers nearly all of the subject parcel (see Figure 5 below).

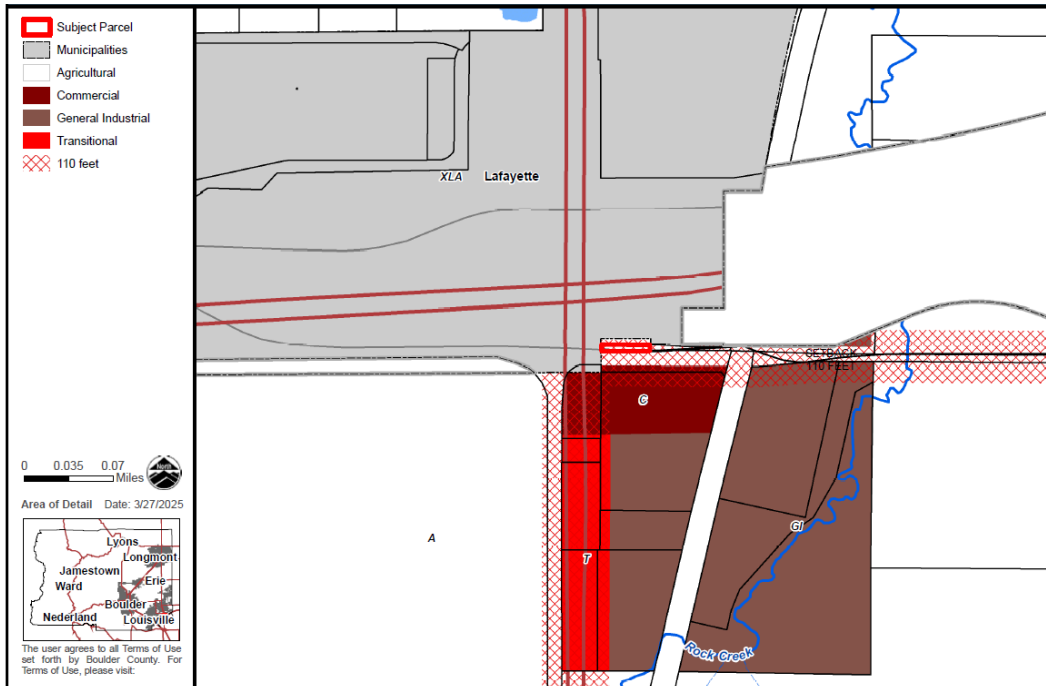

Figure 4: Zoning map, with the subject parcel indicated in red.



Figure 5: Aerial photograph with the subject parcel indicated in red and the supplemental setback indicated in light gray.

PROPOSAL:

The subject parcel has one existing structure of approximately 50 square feet that is used to enclose existing gas regulator equipment; there are also unenclosed gas service lines above ground and buried below ground. To comply with the United States Department of Transportation Pipeline and Hazardous Materials Safety Administration (PHMSA) “Mega Rule” regulations, the applicants intend to construct an approximately 220-square-foot structure to enclose a new regulator station.

In support of this variance request, the applicants provided a hardship statement which indicates that, due to the very small size of the parcel and the location of the existing gas infrastructure, the new utility structure cannot be built to meet the required setbacks. The Code requires that structures in the Agricultural zoning district be located at least 35 feet from the front lot line; additionally, there is a 110-foot supplemental setback from the centerline of Dillion Road. Per the application materials, the new utility structure will be located approximately seven feet from the southern (front) lot line and approximately 28 feet from the centerline of Dillion Road.

REFERRALS:

This application was referred to the typical agencies, departments, and nearby property owners within 1,500 feet of the property. All responses received are attached and summarized below.

Boulder County Building Safety and Inspection Services Team: Boulder County Building Safety and Inspection Services reviewed the proposal and noted that a building permit will be required for the proposed structure and provide information on the applicable building code requirements.

Boulder County Development Review Team – Access & Engineering: Boulder County Development Review Team – Access & Engineering Group (A&E) reviewed the proposal and noted that the subject parcel has demonstrate legal access and stated that they had no conflicts with the proposal.

Agencies that sent a response indicating no conflicts: Boulder County Parks & Open Space – Natural Resources Planner; Boulder County Public Health; City of Lafayette; North Metro Fire Rescue District; and Xcel Energy.

Agencies that did not respond: Boulder County Assessor; Boulder County Long Range Planning; Boulder County Floodplain Team; Colorado Parks & Wildlife; Colorado Department of Regulatory Agencies; and Colorado Department of Transportation.

Adjacent Property Owners: Notices were mailed to the nine property owners within 1,500 feet of the subject parcel. Staff have not received any public comments on the proposal.

CRITERIA ANALYSIS

Per Article 3-100.A.18 of the Code the Board of Adjustment (BOA) may approve a variance from the terms of the Code as set forth in Article 4-1200. To grant a variance, the BOA must find that all of the following criteria of Article 4-1202.B.2 of the Code are satisfied:

- (a) *There exist exceptional or extraordinary physical circumstances of the subject property such as irregularity, narrowness, shallowness, or slope;***

Staff find that the subject parcel is encumbered by extraordinary or exceptional physical circumstances. The subject parcel is extraordinarily small and narrow. The parcel is approximately 0.122 acres in size (approximately 5,309 square feet); specifically, it is approximately 26.5 feet deep, approximately 200 feet long. Per Article 18-175A of the Code, for unsubdivided parcels which are located on a corner, all street frontages are treated as front lot lines. As such, both the southern lot line, which fronts on Dillon Road, and the western lot line, which fronts on US 287, are considered front lot lines and are subject to the required 35-foot front setback required in the Agricultural zoning district. As the subject parcel is only 26.5 feet deep, the required setback from the southern lot line is greater than the depth of the parcel. Therefore, staff find there is no portion of the subject parcel which is outside of the required setbacks for the zoning district. Additionally, the required 110-foot supplemental setback from the centerline of Dillon Road covers all of the subject parcel except for the northern approximately six feet of the parcel. Along with the required 15-foot rear setback required in the Agricultural zoning district, this also eliminates the entirety of the subject parcel of being able to meet setbacks.

Therefore, staff find this criterion is met.

- (b) *Because of these physical circumstances, the strict application of the Code creates an exceptional or undue hardship upon the property owner;***

As discussed above, the small size of the subject parcel means that the subject parcel is constrained from meet the setback requirements. Due to these constraints, staff find the strict application of the Code would create an exceptional hardship upon the property owner.

Therefore, staff find this criterion is met.

- (c) *The hardship is not self-imposed;***

The applicants are undertaking the proposed project in order to comply with Federally mandated changes to the existing gas infrastructure facilities. Staff find that this is a not self-imposed hardship.

Therefore, staff find this criterion is met.

(d) *The variance, if granted, will not adversely affect the uses of adjacent property as permitted under this code;*

Staff do not anticipate that the proposed variance will adversely affect the uses of adjacent properties as permitted under the Code. The land immediately adjacent to the subject parcel is currently used for public rights-of-way; the variance as requested will not change the use of the subject parcel or any of the surrounding land. Additionally, no referral agency responded with any such concerns.

Therefore, staff find this criterion is met.

(e) *The variance, if granted, will not change the character of the zoning district in which the property is located, and is in keeping with the intent of the Code and the Boulder County Comprehensive Plan;*

Staff do not have concerns that the variance will change the character of the zoning district in which the property is located if granted. The subject parcel has been in use for utility infrastructure, since at least the mid-1970s (based on available aerial photographs). Additionally, staff find that the proposed structure is relatively small in size and will not have any adverse visual impacts on the character of the area. Staff find the variance, if granted, will not result in any change of character for the area.

Therefore, staff find that this criterion is met.

(f) *The variance, if granted, does not adversely affect the health, safety, and welfare of the citizens of Boulder County and is in accordance with the Comprehensive Plan and any applicable intergovernmental agreement affecting land use or development.*

Staff have not identified any adverse impacts to the health, safety, and welfare of the citizens of Boulder County which might result from the granting of the variance as requested. As proposed, the new structure for the regulator station will be located back from the public right-of-way, in nearly the same location as the existing structure, with a fence and a vehicle barrier separating the utility structure and infrastructure from vehicular traffic along Dillion Road. Additionally, per the application materials submitted, the proposed structure is necessary for the safe,

secure, and reliable operation of the natural gas system. As such, staff find the proposed structure, and the required variance to construct it, will not adversely affect the health, safety, and welfare of the citizens of Boulder County. Finally, staff have not identified any conflicts with the Boulder County Comprehensive Plan. No referral agencies have responded with any such concerns.

Therefore, staff find this criterion is met.

RECOMMENDATION

As discussed above, staff find that all the criteria for a variance are met. Therefore, Community Planning & Permitting staff recommend that the Board of Adjustment **APPROVE Docket VAR-25-0003: PSCo Setback Reduction.**



Boulder County Land Use Department

Courthouse Annex Building
2045 13th Street • PO Box 471 • Boulder, Colorado 80302
Phone: 303-441-3930 • Fax: 303-441-4856
Email: planner@bouldercounty.org
Web: www.bouldercounty.org/lu
Office Hours: Mon., Wed., Thurs., Fri. 8 a.m. to 4:30 p.m.
Tuesday 10 a.m. to 4:30 p.m.

Shaded Areas for Staff Only

Intake Stamp

Application Form

Project Number		Project Name	
<input type="checkbox"/> Limited Impact Special Use <input type="checkbox"/> Limited Impact Special Use Waiver <input type="checkbox"/> Modification of Special Use <input type="checkbox"/> Site Plan Review <input type="checkbox"/> Site Plan Review Waiver <input type="checkbox"/> Subdivision Exemption <input type="checkbox"/> Exemption Plat <input type="checkbox"/> 1041 State Interest Review <input type="checkbox"/> Other:		Application Deadline: First Wednesday of the Month <input type="checkbox"/> Variance <input type="checkbox"/> Appeal	
		Application Deadline: Second Wednesday of the Month <input type="checkbox"/> Sketch Plan <input type="checkbox"/> Preliminary Plan <input type="checkbox"/> Final Plat <input type="checkbox"/> Resubdivision (Replat) <input type="checkbox"/> Special Use/SSDP	
		<input type="checkbox"/> Rezoning <input type="checkbox"/> Road/Easement Vacation <input type="checkbox"/> Location and Extent <input type="checkbox"/> Road Name Change	
Location(s)/Street Address(es) 11253 Dillon Rd UNINCORPORATED, Boulder, CO 80026			
Subdivision Name Clarkston - LAV			
Lot(s)	Block(s)	Section(s) 14	Township(s) 1 South
Area In Acres .12	Existing Zoning A - Agricultural	Existing Use of Property Electric meter station	Range(s) 69 West
Proposed Water Supply N/A		Proposed Sewage Disposal Method N/A	Number of Proposed Lots 1

Applicants:

Applicant/Property Owner Christian Kopec, Applicant		Email Address ckopec@ws-ls.net	
Mailing Address 505 N Denver Ave			
City Loveland	State CO	Zip Code 80537	Phone 970-308-7330
Applicant/Property Owner/Agent/Consultant Jeremy Bourg, Agent		Email Address Jeremy.J.Bourg@xcelenergy.com	
Mailing Address 1123 W 3rd Avenue			
City Denver	State CO	Zip Code 80223	Phone 303-285-6436
Agent/Consultant		Email Address	
Mailing Address			
City	State	Zip Code	Phone
			Fax

Certification (Please refer to the Regulations and Application Submittal Package for complete application requirements.)

I certify that I am signing this Application Form as an owner of record of the property included in the Application. I certify that the information and exhibits I have submitted are true and correct to the best of my knowledge. I understand that all materials required by Boulder County must be submitted prior to having this matter processed. I understand that public hearings or meetings may be required. I understand that I must sign an Agreement of Payment for Application processing fees, and that additional fees or materials may be required as a result of considerations which may arise in the processing of this docket. I understand that the road, school, and park dedications may be required as a condition of approval.

I understand that I am consenting to allow the County Staff involved in this application or their designees to enter onto and inspect the subject property at any reasonable time, without obtaining any prior consent.

All landowners are required to sign application. If additional space is needed, attach additional sheet signed and dated.

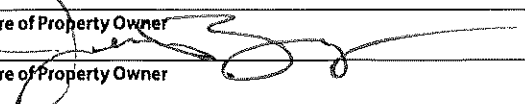
Signature of Property Owner 	Printed Name Jeremy Bourg	Date 6/23/25
Signature of Property Owner	Printed Name	Date

The Land Use Director may waive the landowner signature requirement for good cause, under the applicable provisions of the Land Use Code.







Community Planning & Permitting

2045 13th Street, Boulder, CO 80302 303-441-3930 www.bouldercounty.org

ZONING

11253 Dillon

-  Subject Parcel
-  Municipalities
-  Agricultural
-  Commercial
-  General Industrial
-  Transitional
-  110 feet

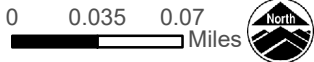
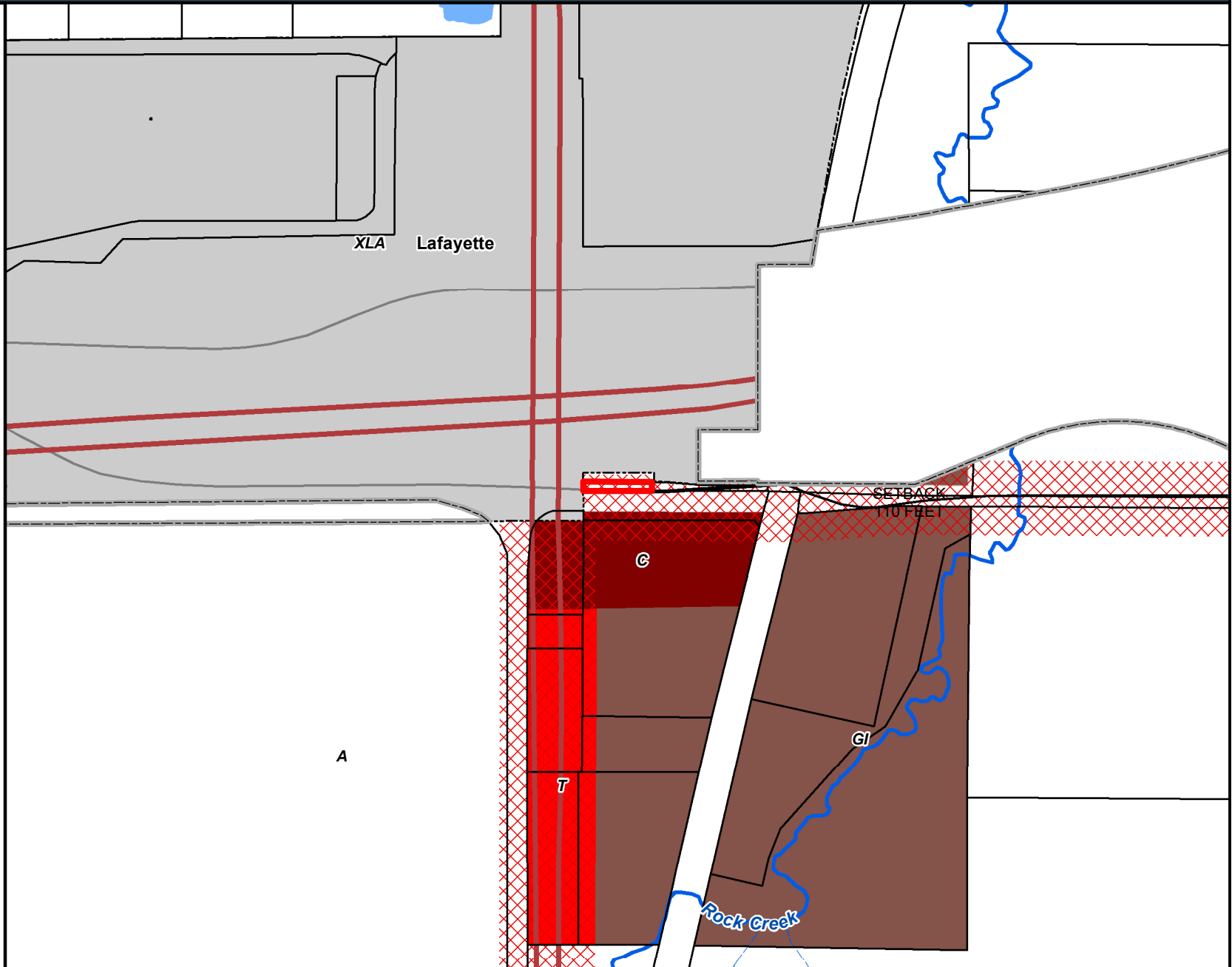

Area of Detail Date: 3/27/2025

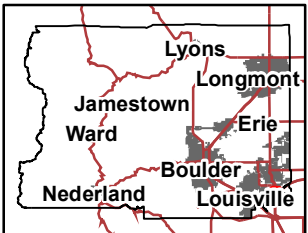

The user agrees to all Terms of Use set forth by Boulder County. For Terms of Use, please visit:





Community Planning & Permitting

2045 13th Street, Boulder, CO 80302 303-441-3930 www.bouldercounty.org

LOCATION

11253 Dillon

-  Subject Parcel
-  Municipalities
-  Subdivisions

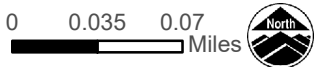
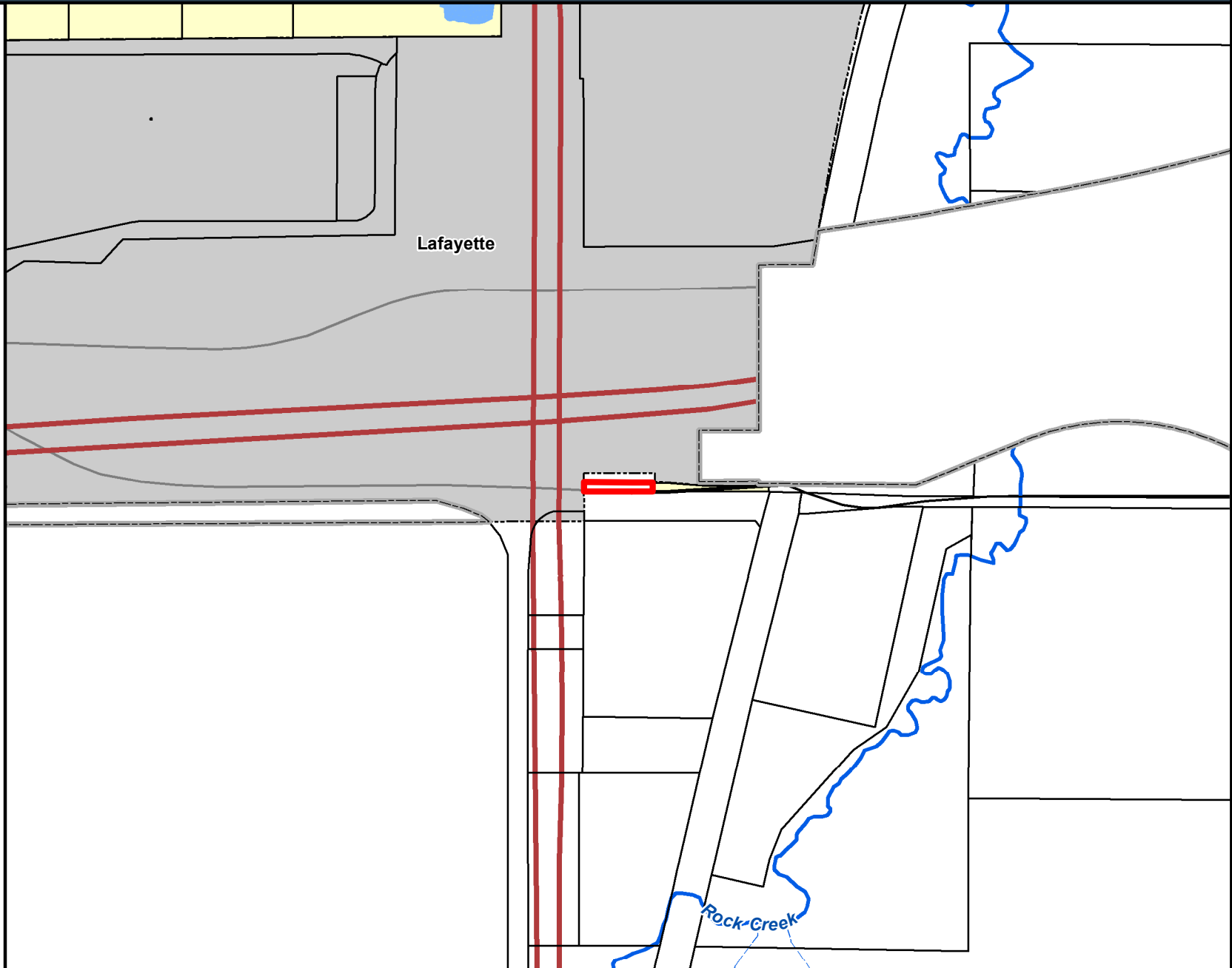

Area of Detail Date: 3/27/2025

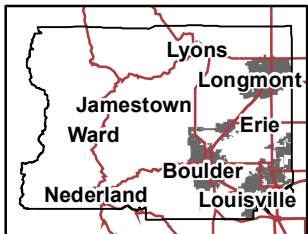

The user agrees to all Terms of Use set forth by Boulder County. For Terms of Use, please visit:





Community Planning & Permitting

2045 13th Street, Boulder, CO 80302 303-441-3930 www.bouldercounty.org

AERIAL

11253 Dillon

-  Subject Parcel
-  Municipalities

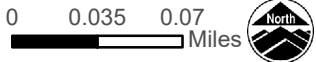
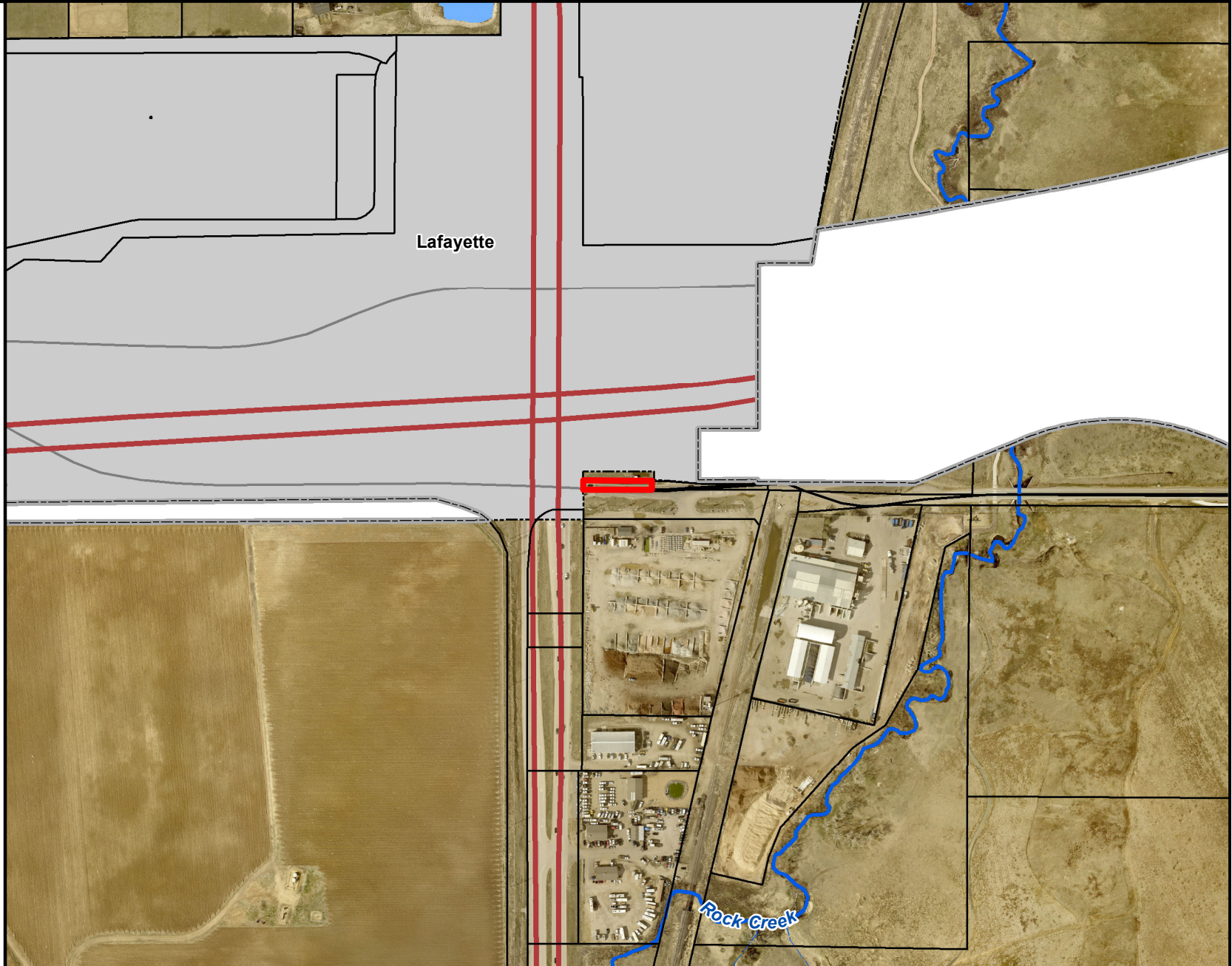

Area of Detail Date: 3/27/2025

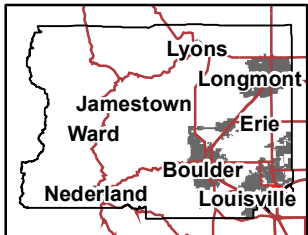

The user agrees to all Terms of Use set forth by Boulder County. For Terms of Use, please visit:





Community Planning & Permitting

2045 13th Street, Boulder, CO 80302 303-441-3930 www.bouldercounty.org

AERIAL

11253 Dillon

-  Subject Parcel
-  Municipalities

Lafayette



0 0.002 0.004 Miles



Area of Detail Date: 3/27/2025

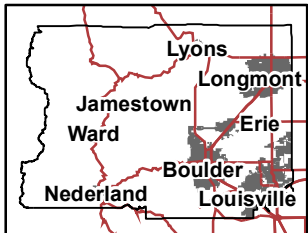

The user agrees to all Terms of Use set forth by Boulder County. For Terms of Use, please visit:



Community Planning & Permitting

2045 13th Street, Boulder, CO 80302 303-441-3930 www.bouldercounty.org

COMPREHENSIVE PLAN

11253 Dillon

-  Subject Parcel
-  Municipalities
-  Archeologically Sensitive Travel Routes
-  Critical Wildlife Habitats
-  Riparian Areas
-  View Protection Corridor Score (Higher is More Scenic)
-  Wetlands
-  Significant Natural Communities
-  National Importance
-  Local Importance

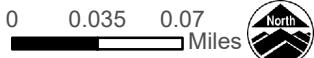
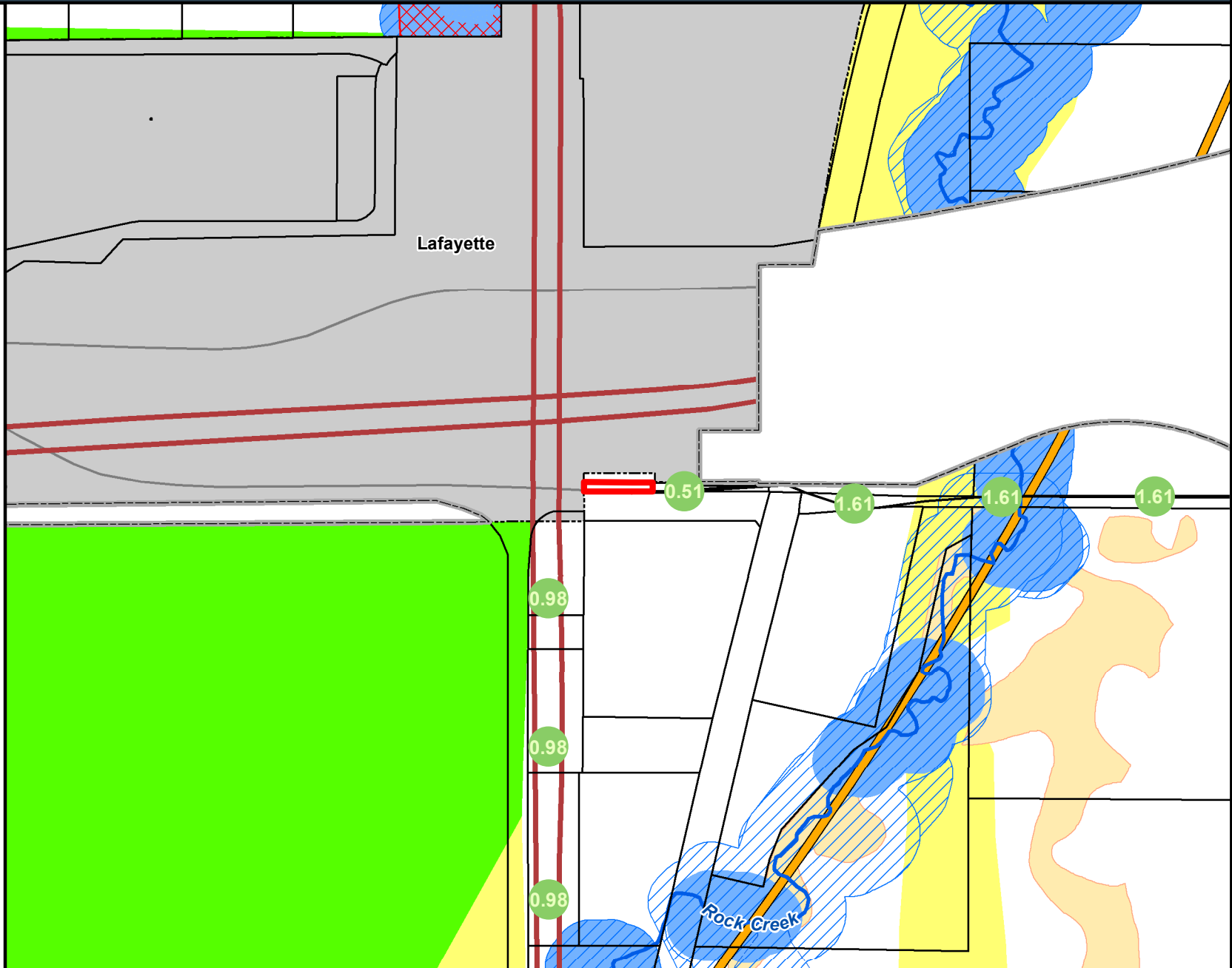

Area of Detail Date: 3/27/2025

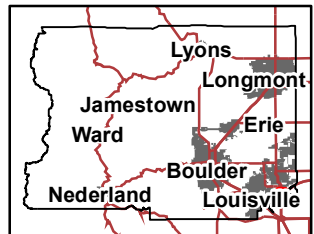

The user agrees to all Terms of Use set forth by Boulder County. For Terms of Use, please visit:



Community Planning & Permitting

2045 13th Street, Boulder, CO 80302 303-441-3930 www.bouldercounty.org

ELEVATION CONTOURS

11253 Dillon

-  Subject Parcel
-  Municipalities
-  Contours 2'

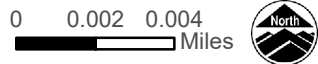
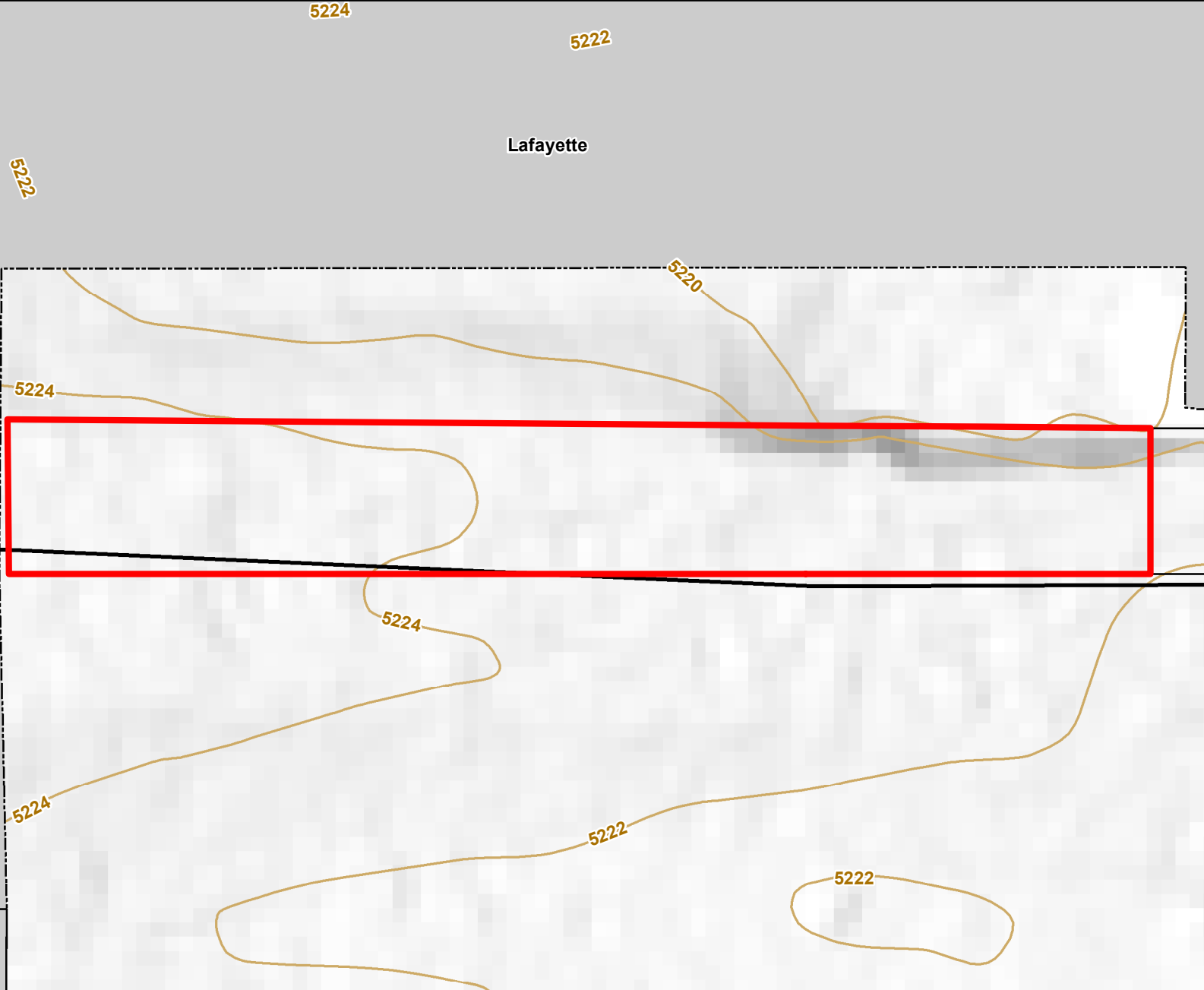

Area of Detail Date: 3/27/2025

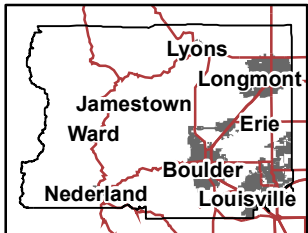

The user agrees to all Terms of Use set forth by Boulder County. For Terms of Use, please visit:







Community Planning & Permitting

2045 13th Street, Boulder, CO 80302 303-441-3930 www.bouldercounty.org

FLOODPLAIN

11253 Dillon

-  Subject Parcel
-  Municipalities
- ZONE_SUBTY**
-  Floodway
-  100-Year Floodplain
-  500-Year Floodplain

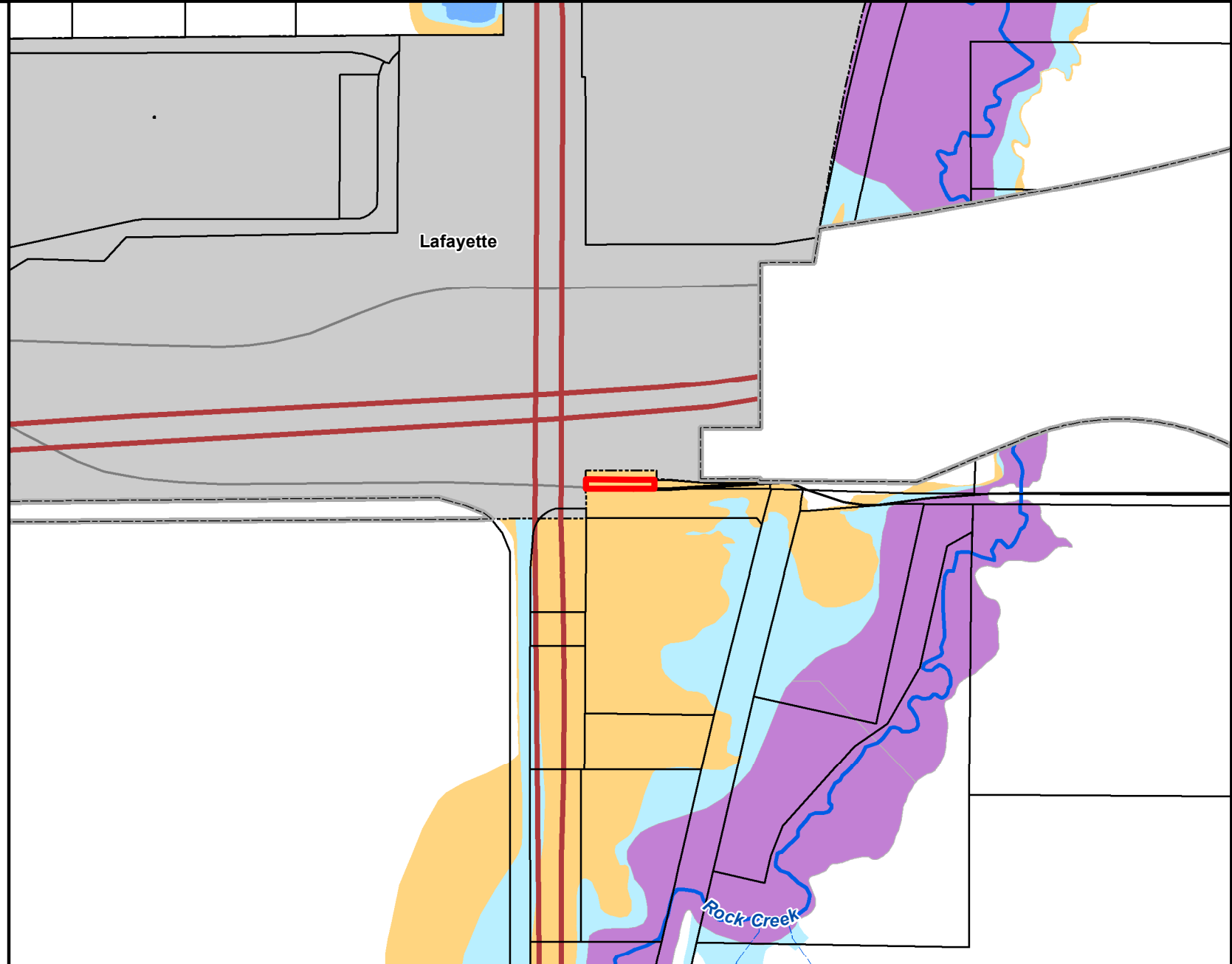

Area of Detail Date: 3/27/2025

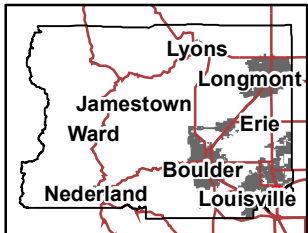

The user agrees to all Terms of Use set forth by Boulder County. For Terms of Use, please visit:









Community Planning & Permitting

2045 13th Street, Boulder, CO 80302 303-441-3930 www.bouldercounty.org

GEOLOGIC HAZARDS

11253 Dillon

-  Subject Parcel
-  Municipalities
-  Extent of Abandoned Coal Mines
-  Landside susceptibility area
-  High
-  Moderate

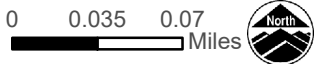
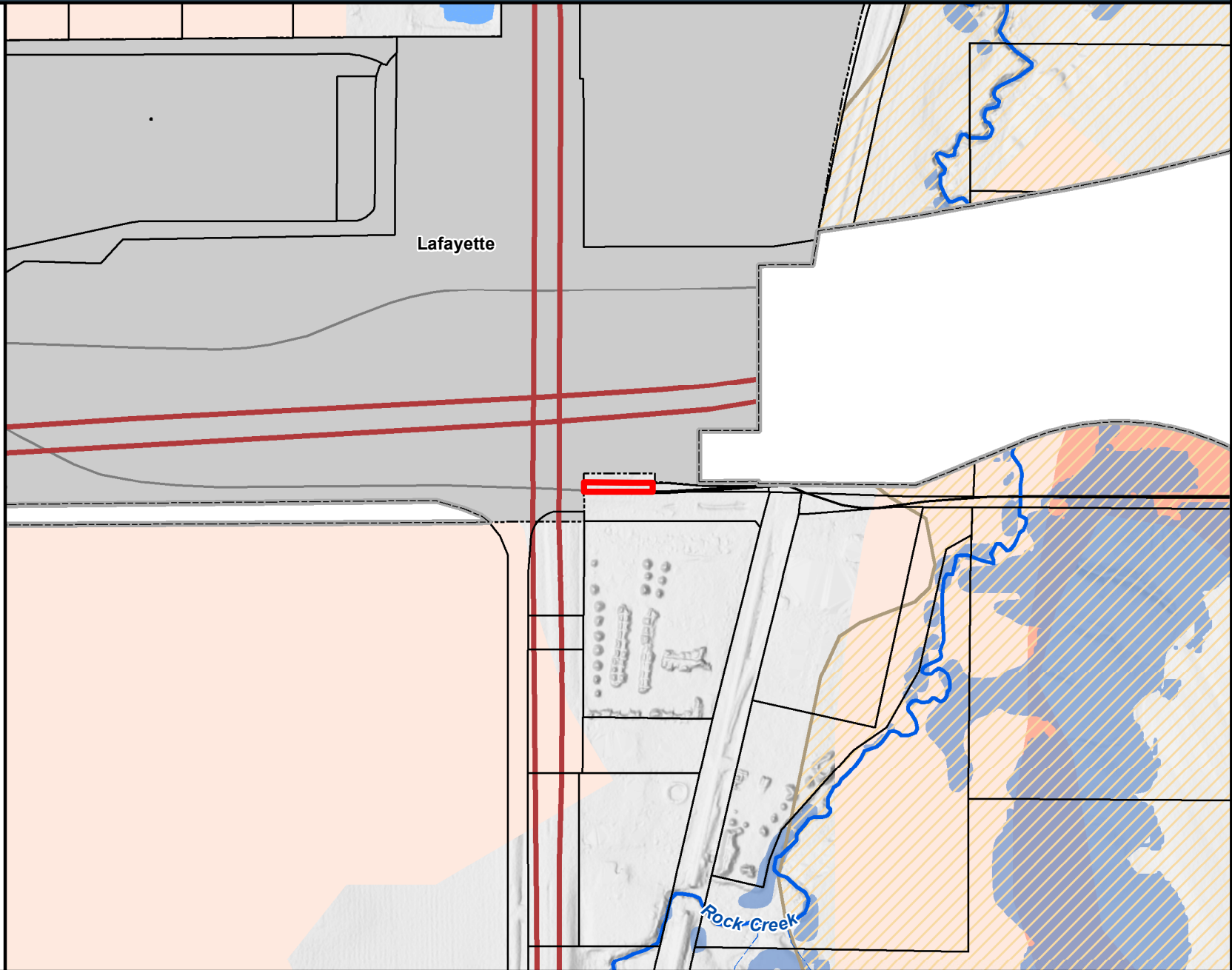

Area of Detail Date: 3/27/2025

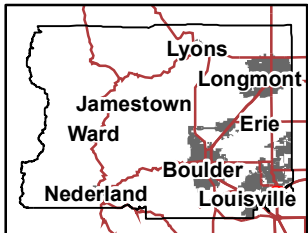

The user agrees to all Terms of Use set forth by Boulder County. For Terms of Use, please visit:







Community Planning & Permitting

2045 13th Street, Boulder, CO 80302 303-441-3930 www.bouldercounty.org

PUBLIC LANDS AND CE'S

11253 Dillon

-  Subject Parcel
-  Municipalities
-  County Open Space
-  County Conservation Easement

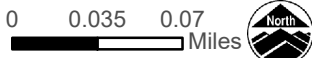
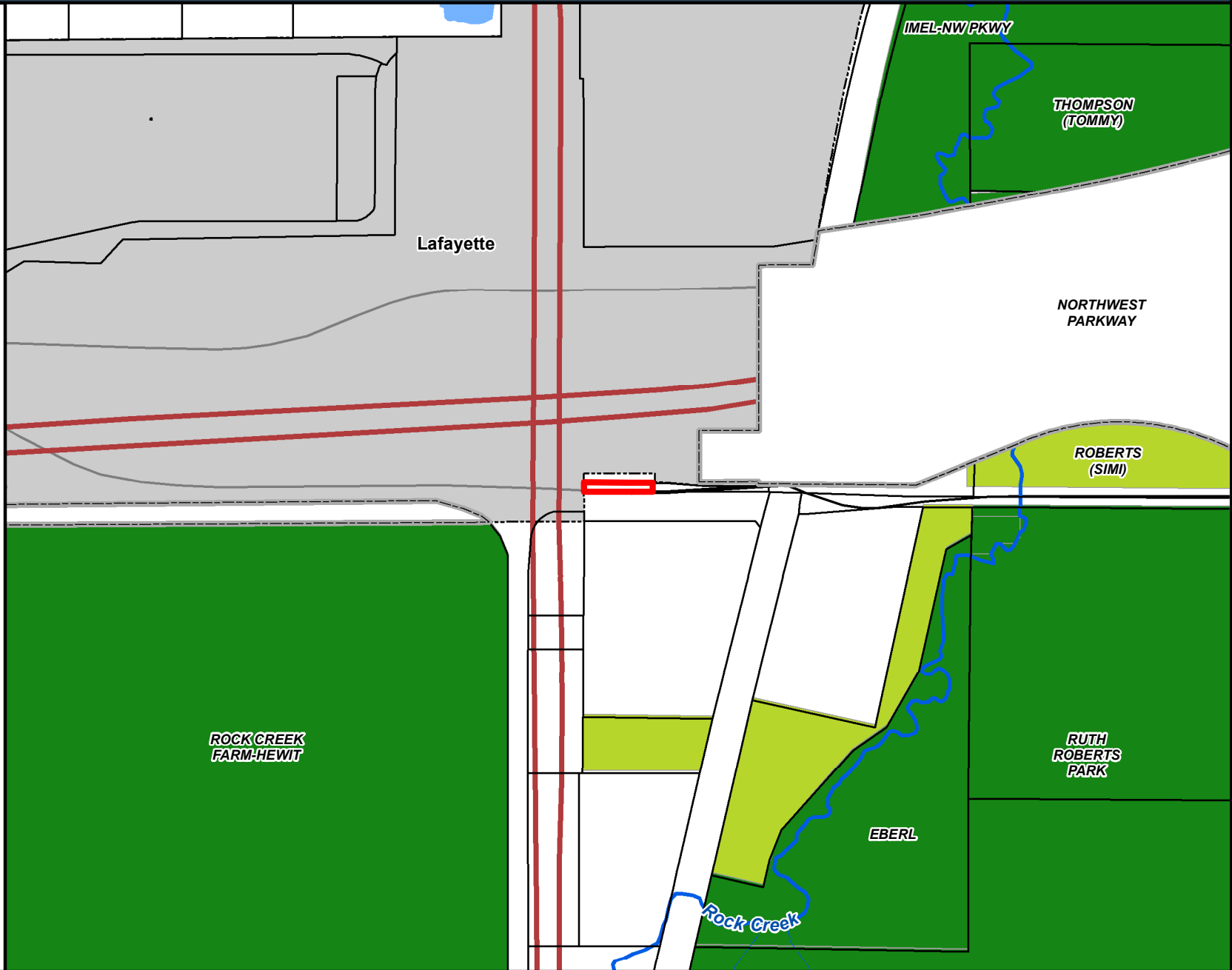

Area of Detail Date: 3/27/2025

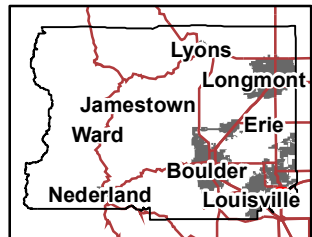

The user agrees to all Terms of Use set forth by Boulder County. For Terms of Use, please visit:



Community Planning & Permitting

2045 13th Street, Boulder, CO 80302 303-441-3930 www.bouldercounty.org

Vicinity

11253 Dillon

- Subject Parcel
- Municipalities
- Subdivisions

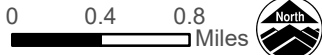
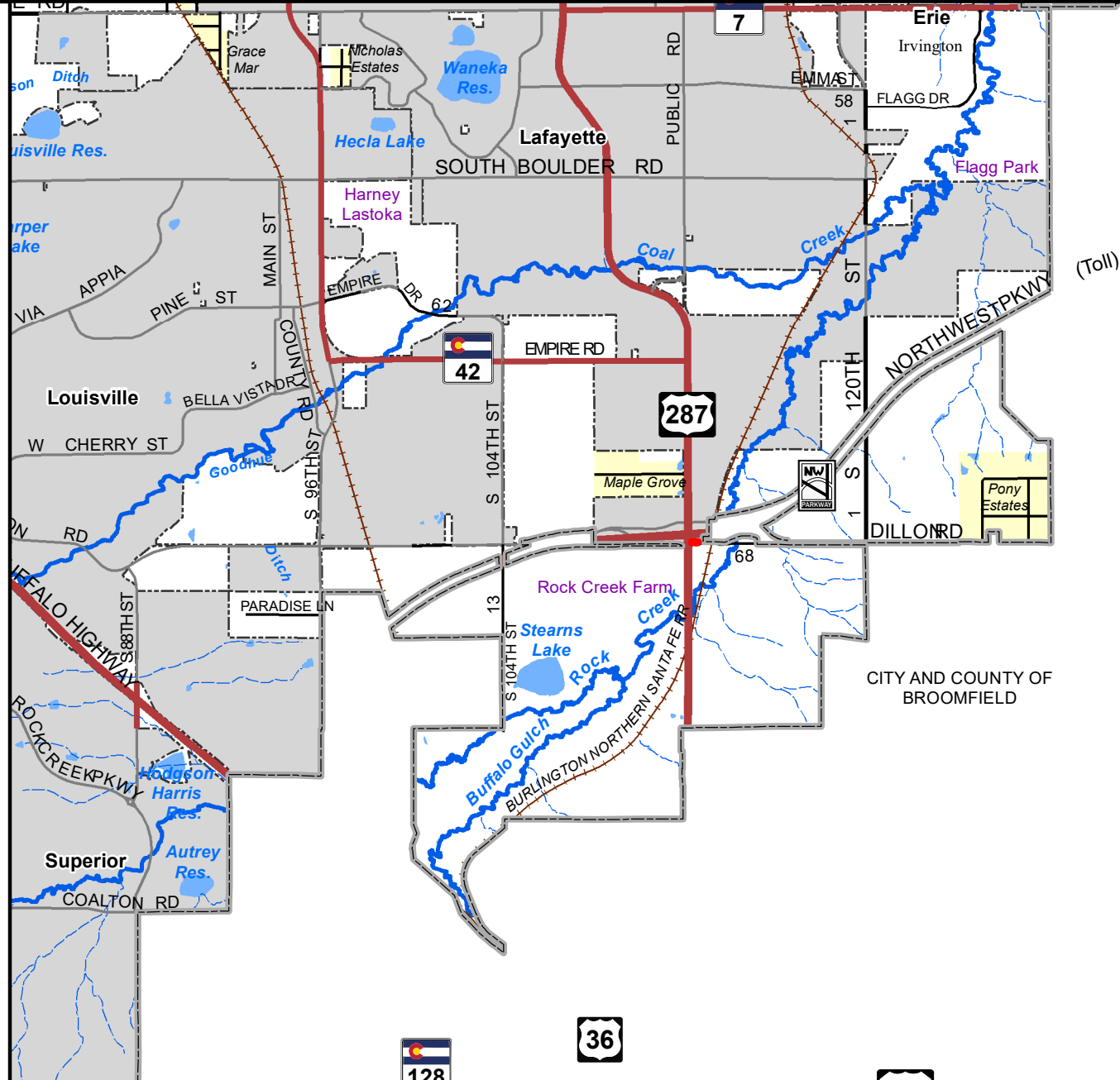

Area of Detail Date: 3/27/2025

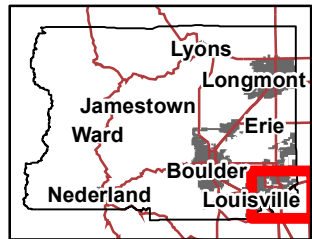

The user agrees to all Terms of Use set forth by Boulder County. For Terms of Use, please visit: www.bouldercounty.org/mapdisclaimer





Boulder County Land Use Department
 Courthouse Annex Building • 2045 13th Street • PO Box 471
 Boulder, Colorado 80302
 Phone: 303-441-3930 • Fax: 303-441-4856
 Email: planner@bouldercounty.org
<http://www.bouldercounty.org/lu/>
 Office Hours: Monday — Friday 8:00 AM to 4:30 PM

Intake Stamp:
Docket #:

Board of Adjustment (BOA) Hardship Statement

Explain how the following hardship criteria for granting a variance have been satisfied. Please feel free to attach your statements using a separate piece of paper.

A. There exists exceptional or extraordinary physical circumstances of the subject property such as irregularity, narrowness, shallowness, or slope.

The subject property is exceptionally small, approximately 1/8 of an acre directly north of Dillon Road. Boulder County currently requires a 35 foot setback but the existing setback to the south is only approximately 18 feet. Procurement of additional land from Northwest Parkway would place the site in a water drainage area.

B. Because of these physical circumstances, the strict application of this Code would create an exceptional or undue hardship up the property owner.

Because the buildable envelope of the subject property is reduced by setbacks as well as the proximity to a water drainage area, strict enforcement of the code would not allow for Xcel Energy to protect the rebuilt regulators with the proposed enclosure. The proposed enclosure is necessary to protect the rebuilt natural gas regulators from vandalism or severe weather and provide operations staff a safe work environment to perform maintenance on the system during inclement weather. Procurement of additional land from Northwest Parkway is not economically feasible, nor is a complete relocation of existing infrastructure.

C. The hardship is not self-imposed.

The E-72 Bailey Group project resides within the Boulder County jurisdiction and was initially constructed prior to the current Boulder County Agricultural setback rules. The rebuild of the natural gas regulators is a federal requirement by the Pipeline and Hazardous Materials Safety Administration (PHMSA) to produce Traceable, Verifiable, and Complete (TVC) records for the regulator station, not an electric undertaking by Xcel Energy. Construction of the Northwest Parkway was completed long after this Xcel Energy infrastructure was in service, further restricting options allowing them to achieve the required setback.

D. The variance, if granted, will not adversely affect the use of adjacent property as permitted under this Code.

The location of the rebuilt regulators and proposed enclosure is in the same general location as existing regulators and their enclosure. The existing setback to the south of approximately 18 feet would be maintained. A temporary construction easement is being negotiated with the adjacent property owner, and the footprint of such an area will be reclaimed to match existing conditions unless otherwise requested by the landowner.

E. That the variance, if granted, will not change the character of the zoning district in which the property is located, and is in keeping with the intent of this Code and the Boulder County Comprehensive Plan; and,

The variance would allow Xcel Energy to install an enclosure around the rebuilt regulator station equipment, in a similar style and location to what currently exists at the site. There is no proposed change of use at the site and no increase in capacity or supply of the current natural gas distribution system. The site will operate as it currently does, with modernized infrastructure, and therefore will be in keeping with the intent of the Code and the Boulder County Comprehensive Plan.

F. That the variance, if granted, does not adversely affect the health, safety, and welfare of the citizens of Boulder County.

The variance would allow Xcel Energy to protect the rebuilt regulator station equipment with a metal, prefabricated enclosure. Such an enclosure is necessary for the safe, secure, and reliable operation of the natural gas system. Such enclosures protect natural gas regulators from severe weather conditions and potential vandalism, and allow for safe access for operations and maintenance staff who must perform maintenance in adverse weather conditions. The Project will allow for continued supply of safe, reliable energy to existing customers and does not increase capacity or supply of the current natural gas distribution system.

Applicant or Agent Signature: 	Date: 6/23/25
---	---------------

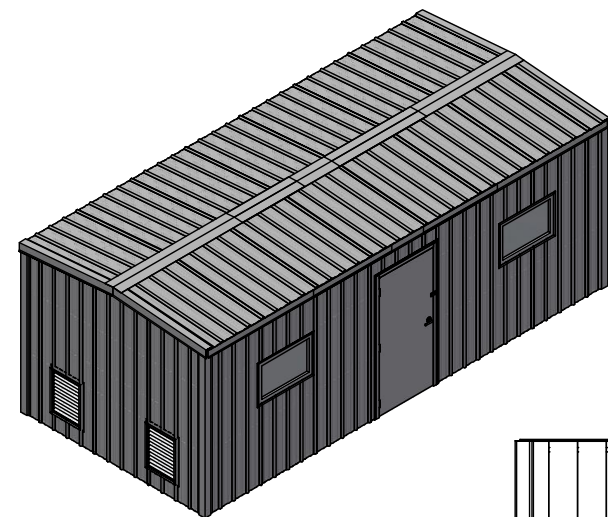

QTY-1
(B.O.M. IS FOR A QTY OF 1)

NOTES:
1. APPROX WEIGHT: 3800 LBS

BILL OF MATERIAL		
ITEM	QTY	DESCRIPTION
1	1	BUILDING FRAME: PER DETAIL
2	2	DOOR: SINGLE, 3' X 6'-8", W/ FRAME, HINGES, SEALS, NON-LOCKING HANDLE, SWEEP, & DOOR CLOSER
3	4	WINDOW: 36" X 23"
4	4	LOUVER: 18" X 24", ALUMINUM, MCMMASTER-CARR 2038K21
5	4	J CHANNEL TRIM: 26 GA X 7'-0 1/4" LONG, FLATIRON STEEL TUF RIB
6	2	J CHANNEL TRIM: 26 GA X 3'-8 1/2" LONG, FLATIRON STEEL TUF RIB
7	8	J CHANNEL TRIM: 26 GA X 3'-3 7/8" LONG, FLATIRON STEEL TUF RIB
8	8	J CHANNEL TRIM: 26 GA X 2'-3 7/8" LONG, FLATIRON STEEL TUF RIB
9	8	J CHANNEL TRIM: 26 GA X 1'-10 3/8" LONG, FLATIRON STEEL TUF RIB
10	8	J CHANNEL TRIM: 26 GA X 2'-4 3/8" LONG, FLATIRON STEEL TUF RIB
11	8	PANEL: 26 GA X 36" WIDE X 8'-4" LONG, FLATIRON STEEL TUF RIB
12	16	PANEL: 26 GA X 36" WIDE X 7'-11" LONG, FLATIRON STEEL TUF RIB
13	16	PANEL: 26 GA X 36" WIDE X 5'-0" LONG, FLATIRON STEEL TUF RIB
14	6	EAVE TRIM: 26 GA X 10'-2" LONG, STYLE A, X=3-1/2", 1:12 SLOPE, FLATIRON STEEL TUF RIB
15	4	OUTSIDE CORNER TRIM: 26GA X 7'-11 3/4" LONG, FLATIRON STEEL TUF RIB
16	4	RAKE TRIM: 26 GA X 63" LONG, X=4-1/4", FLATIRON STEEL TUF RIB
17	3	VENTED RIDGE CAP: 26GA X 11" WIDE X 10'-2" LONG, 1:12 SLOPE, FLATIRON STEEL TUF RIB
18	2	PADLOCK HASP: STEEL
--	--	BAFFLED RIDGE VENT
--	500	SCREW: #12 X 1", SELF DRILL
--	500	SCREW: STITCH, #14 X 7/8", SELF DRILL
--	--	FOAM INSIDE CLOSURE: FLATIRON STEEL TUF RIB
--	--	FOAM OUTSIDE CLOSURE: FLATIRON STEEL TUF RIB

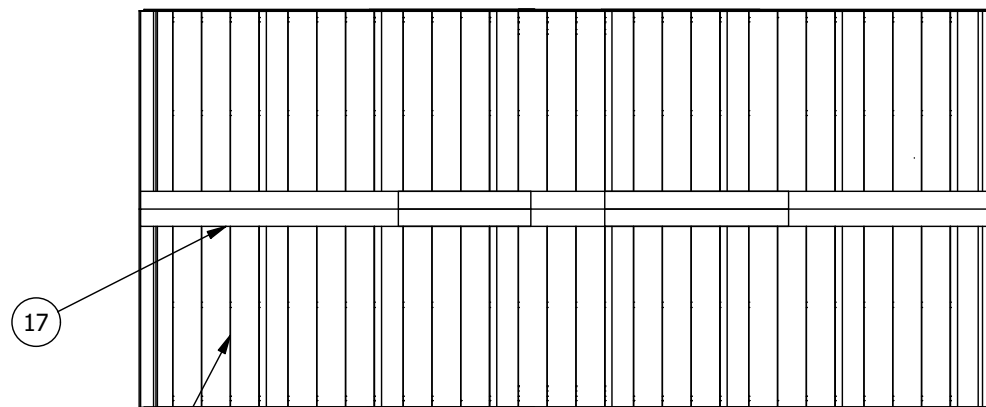

TOP VIEW
SCALE 1 / 60

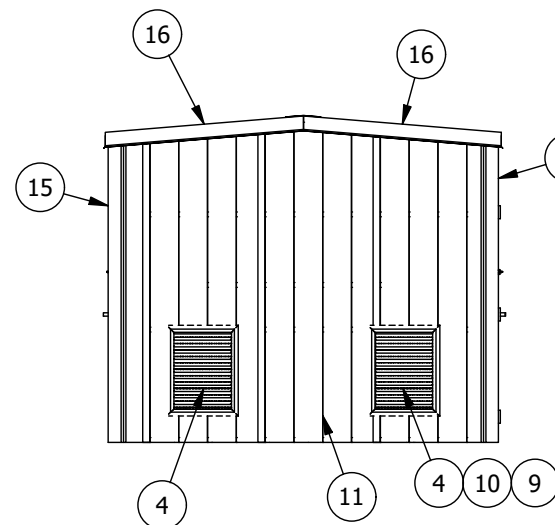

LEFT VIEW
SCALE 1 / 60

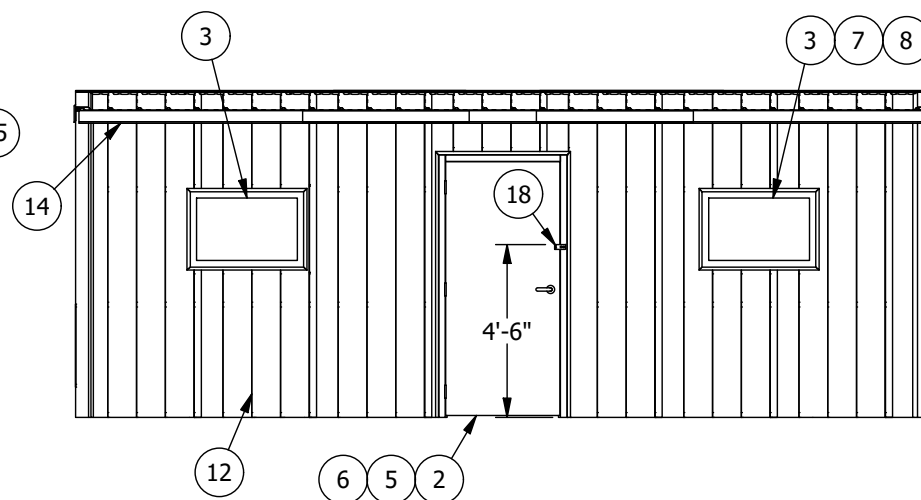

FRONT VIEW
SCALE 1 / 60

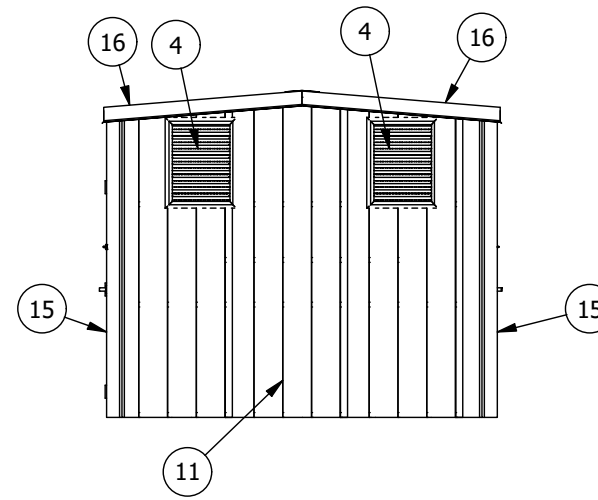

RIGHT VIEW
SCALE 1 / 60

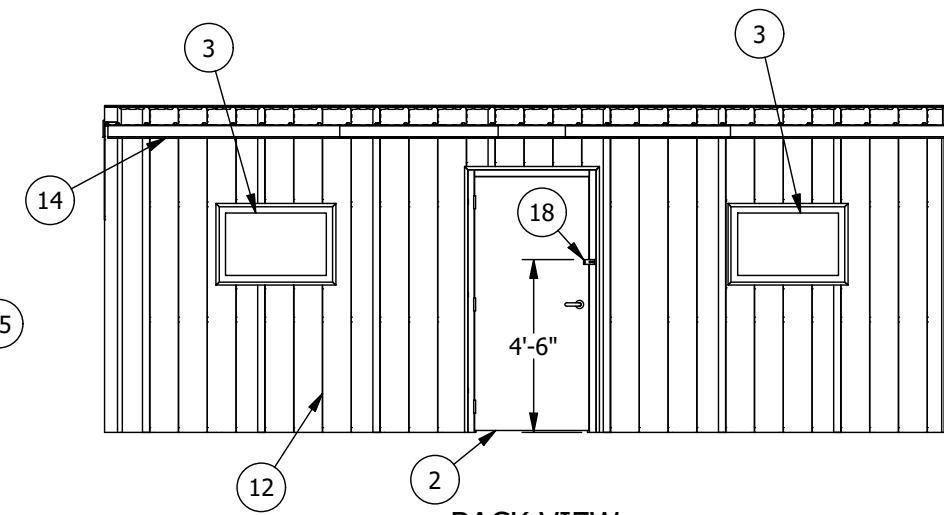

BACK VIEW
SCALE 1 / 60

REVISIONS

REV.	DESCRIPTION	BY	DATE
0	ISSUED FOR CONSTRUCTION	EE	4-28-25

GENERAL TOLERANCES:
(UNLESS OTHERWISE SPECIFIED)
SINGLE PART FRACTIONAL: ±1/16"
FABRICATION FRACTIONAL STACK-UP:
0" - 48": ± 1/8"
48" - 96": ± 3/16"
OVER 96": ± 1/4"
ANGLES: ± 1/2°
WELD SIZES ARE MINIMUMS
DEBURR & BREAK SHARP EDGES

THIS DRAWING IS THE PROPERTY OF BLACKEAGLE FABRICATION LLC AND UNLESS GRANTED IN WRITING, DESIGN INFORMATION DISCLOSED WITHIN IS CONFIDENTIAL AND ALL RIGHTS, PATENTS AND OTHERWISE ARE RESERVED BY BLACKEAGLE FABRICATION LLC. DRAWINGS MUST BE SURRENDERED UPON REQUEST.
© ALL RIGHTS RESERVED.



230 COMMERCE DRIVE, BERTHOUD CO, 80513
PHONE: (970) 532-0600 - FAX: (970) 532-4846

BES / XCEL ENERGY

BAILEY GROUP MS BUILDING
SHOP FABRICATION DETAILS

DRAWING APPROVALS

CLIENT	PROJECT MGR.	PROJECT ENG.	QUALITY CONTROL

DRAWN DATE:	JOBBOSS #:	DRAWING #:	REV
4/28/2025		225XXX CS-101	0
DRAWN BY:	E. ELLIS	ENGINEER:	

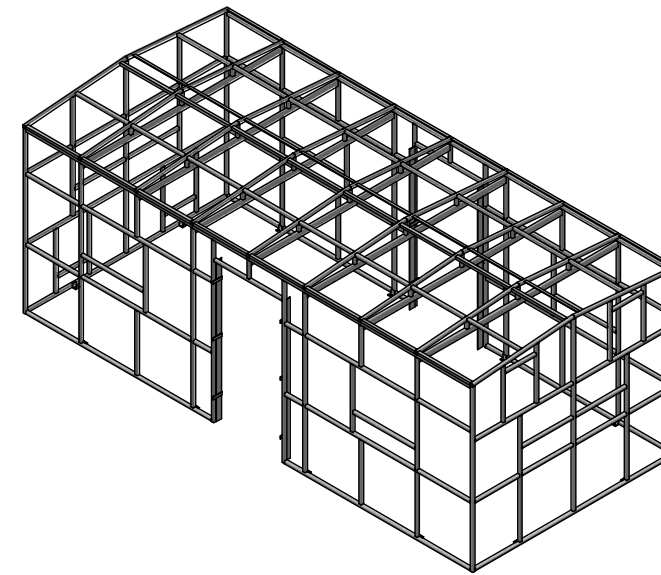
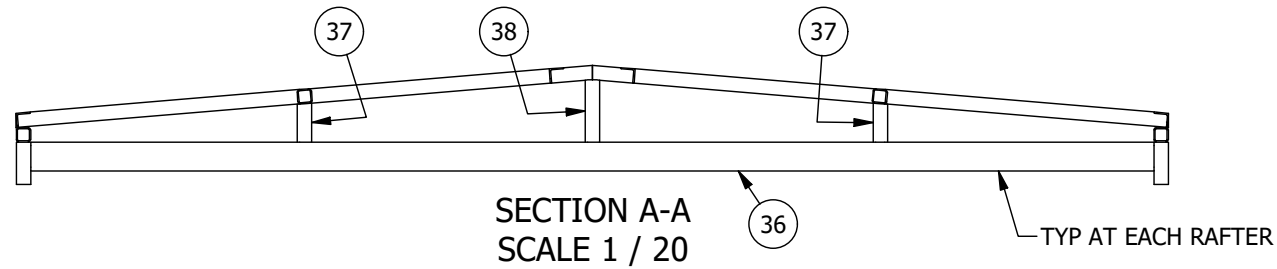

BILL OF MATERIAL		
ITEM	QTY	DESCRIPTION
30	2	WALL: PER DETAIL
31	1	WALL: PER DETAIL
32	1	WALL: PER DETAIL
33	1	ROOF: PER DETAIL
34	4	PLATE: 3/16" X 3-1/8" X 82", A-36
35	12	PLATE: 3/16" X 1-1/2" X 5-1/4", A-36
36	7	RECT TUBE: 3" x 1-1/2" x 3/16", ASTM A500 GR B
37	14	SQ TUBE: 1-1/2" x 1-1/2" x 10 GA, ASTM A500 GR B, PER DETAIL
38	7	SQ TUBE: 1-1/2" x 1-1/2" x 10 GA, ASTM A500 GR B, PER DETAIL

QTY-1
(B.O.M. IS FOR A QTY OF 1)

- NOTES:
 1. APPROX WEIGHT: 1800 LBS
 2. WPS 1A-17
 3. SURFACE FINISH: PAINTED

ITEMS 34 & 35 WELD ON DURING DOOR FRAME FIT

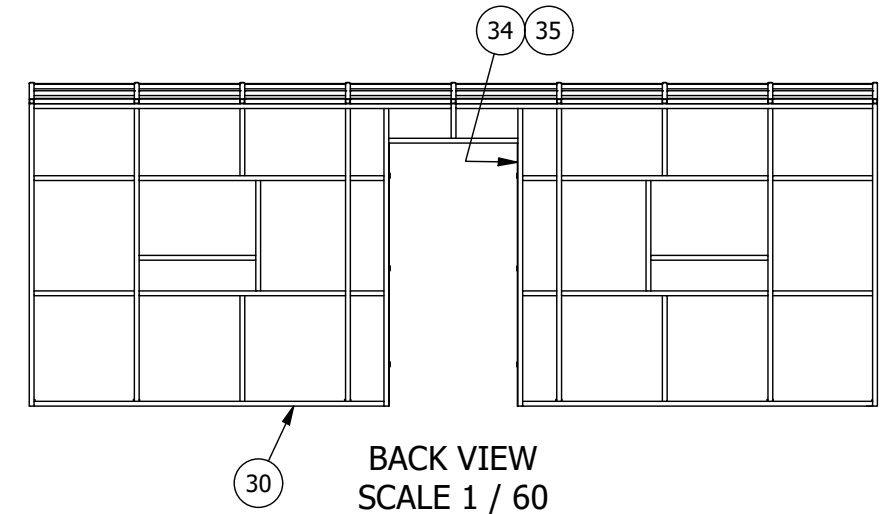
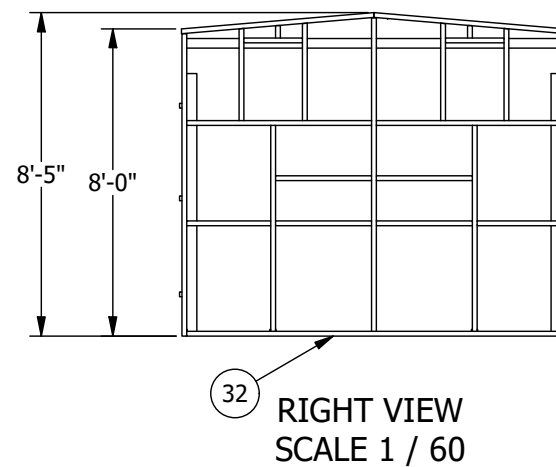
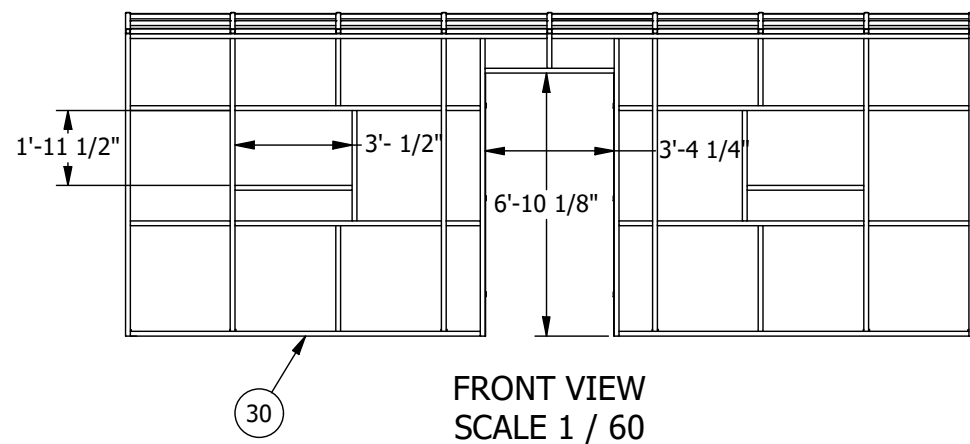
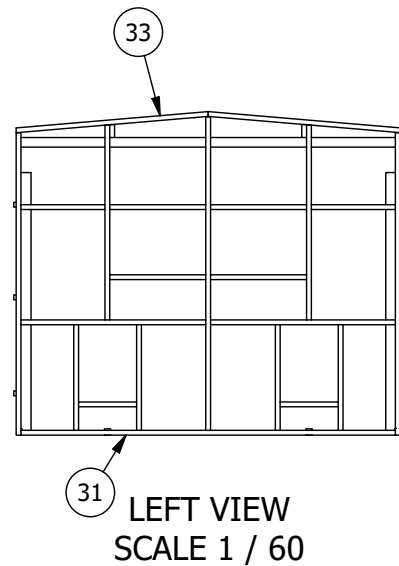
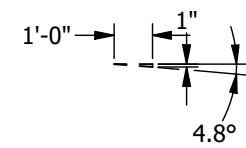
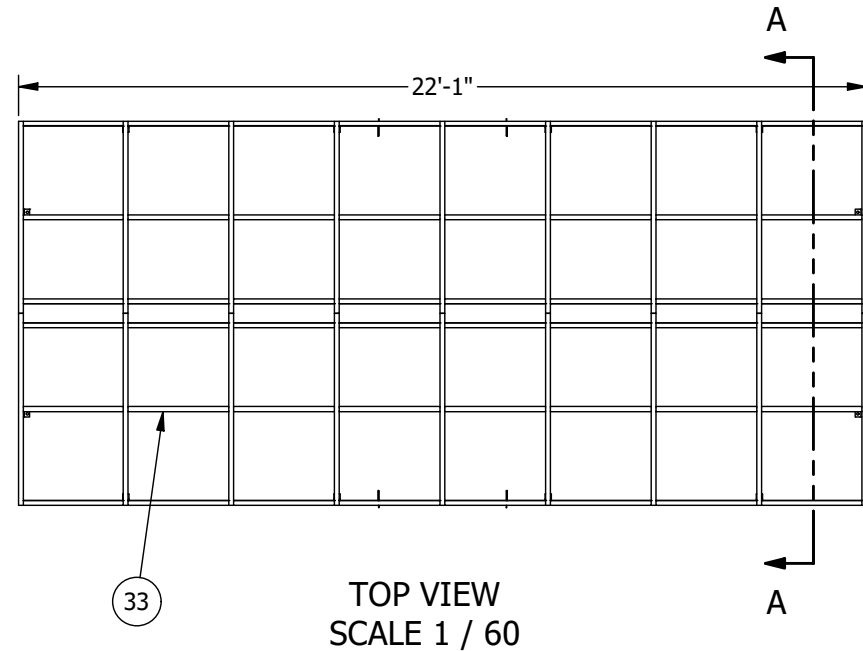

REVISIONS			
REV.	DESCRIPTION	BY	DATE
0	ISSUED FOR CONSTRUCTION	EE	4-28-25

GENERAL TOLERANCES:
 (UNLESS OTHERWISE SPECIFIED)
 SINGLE PART FRACTIONAL: ±1/16"
 FABRICATION FRACTIONAL STACK-UP:
 0" - 48": ± 1/8"
 48" - 96": ± 3/16"
 OVER 96": ± 1/4"
 ANGLES: ± 1/2°
 WELD SIZES ARE MINIMUMS
 DEBURR & BREAK SHARP EDGES

THIS DRAWING IS THE PROPERTY OF BLACKEAGLE FABRICATION LLC AND UNLESS GRANTED IN WRITING, DESIGN INFORMATION DISCLOSED WITHIN IS CONFIDENTIAL AND ALL RIGHTS, PATENTS AND OTHERWISE ARE RESERVED BY BLACKEAGLE FABRICATION LLC. DRAWINGS MUST BE SURRENDERED UPON REQUEST.
 © ALL RIGHTS RESERVED.

BLACKEAGLE FABRICATION, LLC

230 COMMERCE DRIVE, BERTHOUD CO, 80513
 PHONE: (970) 532-0600 - FAX: (970) 532-4846

BES / XCEL ENERGY				
DRAWING APPROVALS				
APPVD BY:	CLIENT	PROJECT MGR.	PROJECT ENG.	QUALITY CONTROL
DATE				

BAILEY GROUP MS BUILDING SHOP FABRICATION DETAILS			
DRAWN DATE:	JOBBOSS #:	DRAWING #:	REV
4/28/2025		225XXX CS-101	0
DRAWN BY:	E. ELLIS	ENGINEER:	

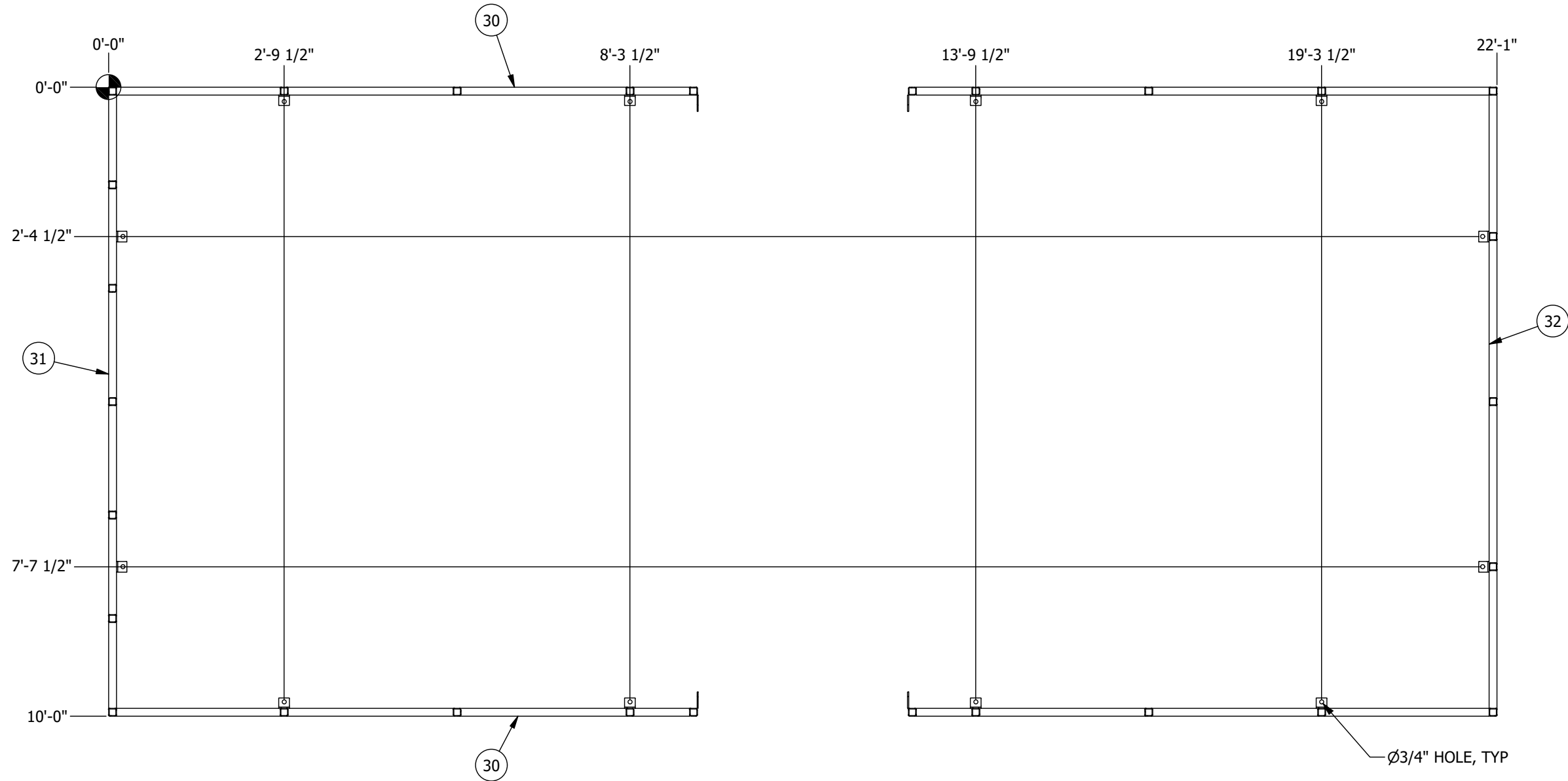
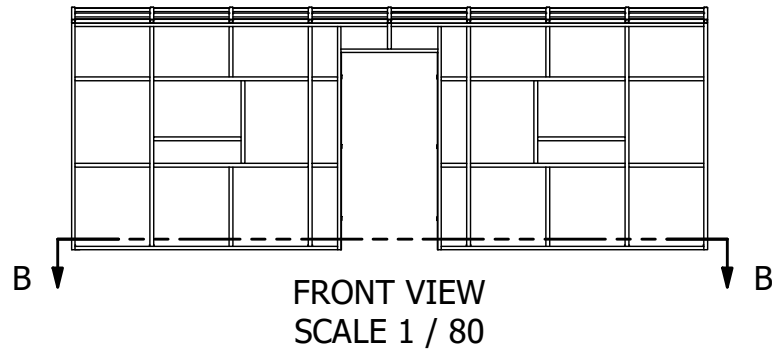

SECTION B-B
SCALE 1 / 24

REVISIONS

REV.	DESCRIPTION	BY	DATE
0	ISSUED FOR CONSTRUCTION	EE	4-28-25

GENERAL TOLERANCES:
(UNLESS OTHERWISE SPECIFIED)
SINGLE PART FRACTIONAL: ±1/16"
FABRICATION FRACTIONAL STACK-UP:
0" - 48": ± 1/8"
48" - 96": ± 3/16"
OVER 96": ± 1/4"
ANGLES: ± 1/2°
WELD SIZES ARE MINIMUMS
DEBURR & BREAK SHARP EDGES

THIS DRAWING IS THE PROPERTY OF BLACKEAGLE FABRICATION LLC AND UNLESS GRANTED IN WRITING, DESIGN INFORMATION DISCLOSED WITHIN IS CONFIDENTIAL AND ALL RIGHTS, PATENTS AND OTHERWISE ARE RESERVED BY BLACKEAGLE FABRICATION LLC. DRAWINGS MUST BE SURRENDERED UPON REQUEST.
© ALL RIGHTS RESERVED.



230 COMMERCE DRIVE, BERTHOUD CO, 80513
PHONE: (970) 532-0600 - FAX: (970) 532-4846

BES / XCEL ENERGY

DRAWING APPROVALS

	CLIENT	PROJECT MGR.	PROJECT ENG.	QUALITY CONTROL
APPVD BY:				
DATE				

BAILEY GROUP MS BUILDING
SHOP FABRICATION DETAILS

DRAWN DATE:	JOBBOSS #:	DRAWING #:	REV
4/28/2025		225XXX CS-101	0
DRAWN BY:	E. ELLIS	ENGINEER:	



BILL OF MATERIAL			
ITEM	QTY	DESCRIPTION	LENGTH
40	2	SQ TUBE: 1-1/2" x 1-1/2" x 11 GA, ASTM A500 GR B	10'-10 1/4"
41	2	SQ TUBE: 1-1/2" x 1-1/2" x 11 GA, ASTM A500 GR B	9'-1 3/8"
42	2	SQ TUBE: 1-1/2" x 1-1/2" x 11 GA, ASTM A500 GR B	7'-10 1/2"
43	2	SQ TUBE: 1-1/2" x 1-1/2" x 11 GA, ASTM A500 GR B	7'-9"
44	4	SQ TUBE: 1-1/2" x 1-1/2" x 11 GA, ASTM A500 GR B	7'-7 1/2"
45	4	SQ TUBE: 1-1/2" x 1-1/2" x 11 GA, ASTM A500 GR B	5'-4 1/2"
46	1	SQ TUBE: 1-1/2" x 1-1/2" x 11 GA, ASTM A500 GR B	3'-4 1/4"
47	2	SQ TUBE: 1-1/2" x 1-1/2" x 11 GA, ASTM A500 GR B	3'- 1/2"
48	2	SQ TUBE: 1-1/2" x 1-1/2" x 11 GA, ASTM A500 GR B	2'-10 1/2"
49	2	SQ TUBE: 1-1/2" x 1-1/2" x 11 GA, ASTM A500 GR B	2'-9"
50	4	SQ TUBE: 1-1/2" x 1-1/2" x 11 GA, ASTM A500 GR B	2'-7 1/4"
51	2	SQ TUBE: 1-1/2" x 1-1/2" x 11 GA, ASTM A500 GR B	1'-9"
52	1	SQ TUBE: 1-1/2" x 1-1/2" x 11 GA, ASTM A500 GR B	10 7/8"
53	4	SQ TUBE: 1-1/2" x 1-1/2" x 11 GA, ASTM A500 GR B	10 5/8"
54	4	ANGLE: L2" x 2" x 1/4", ASTM A-36, PER DETAIL	2"

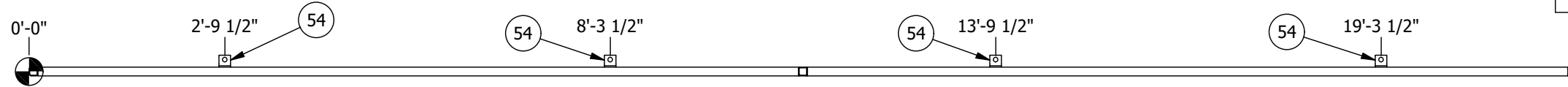

QTY-2
(B.O.M. IS FOR A QTY OF 1)

NOTES:
1. APPROX WEIGHT: 350 LBS
2. WPS 1A-17

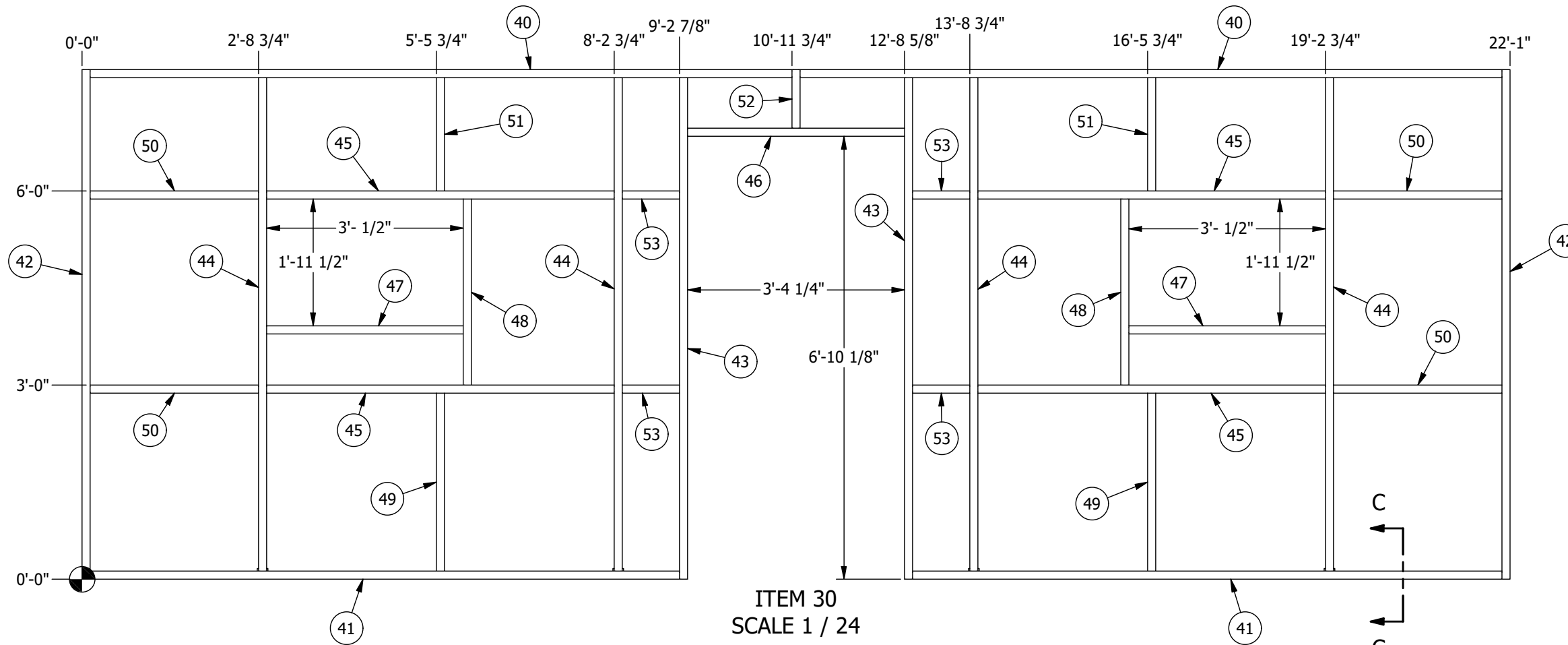

ITEM 30
SCALE 1 / 24
**VERIFY WINDOW SIZE
BEFORE WELDING**

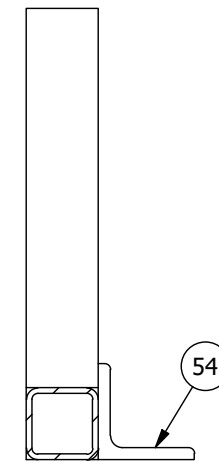

SECTION C-C
SCALE 1 / 4

REVISIONS			
REV.	DESCRIPTION	BY	DATE
0	ISSUED FOR CONSTRUCTION	EE	4-28-25

GENERAL TOLERANCES:
(UNLESS OTHERWISE SPECIFIED)
SINGLE PART FRACTIONAL: ±1/16"
FABRICATION FRACTIONAL STACK-UP:
0" - 48": ± 1/8"
48" - 96": ± 3/16"
OVER 96": ± 1/4"
ANGLES: ± 1/2°
WELD SIZES ARE MINIMUMS
DEBURR & BREAK SHARP EDGES

THIS DRAWING IS THE PROPERTY OF BLACKEAGLE FABRICATION LLC AND UNLESS GRANTED IN WRITING, DESIGN INFORMATION DISCLOSED WITHIN IS CONFIDENTIAL AND ALL RIGHTS, PATENTS AND OTHERWISE ARE RESERVED BY BLACKEAGLE FABRICATION LLC. DRAWINGS MUST BE SURRENDERED UPON REQUEST.
© ALL RIGHTS RESERVED.

BLACKEAGLE
FABRICATION, LLC



230 COMMERCE DRIVE, BERTHOUD CO, 80513
PHONE: (970) 532-0600 - FAX: (970) 532-4846

BES / XCEL ENERGY

BAILEY GROUP MS BUILDING
SHOP FABRICATION DETAILS

DRAWING APPROVALS			
APPVD BY:	CLIENT	PROJECT MGR.	PROJECT ENG.

DRAWN DATE:	JOBBOSS #:	DRAWING #:	REV
4/28/2025		225XXX CS-101	0
DRAWN BY:	E. ELLIS	ENGINEER:	

BILL OF MATERIAL

ITEM	QTY	DESCRIPTION	LENGTH
54	2	ANGLE: L2" x 2" x 1/4", ASTM A-36, PER DETAIL	2"
55	1	SQ TUBE: 1-1/2" x 1-1/2" x 11 GA, ASTM A500 GR B	9'-9"
56	1	SQ TUBE: 1-1/2" x 1-1/2" x 11 GA, ASTM A500 GR B, PER DETAIL	8'-2"
57	2	SQ TUBE: 1-1/2" x 1-1/2" x 11 GA, ASTM A500 GR B, PER DETAIL	5'- 15/16"
58	2	SQ TUBE: 1-1/2" x 1-1/2" x 11 GA, ASTM A500 GR B	4'-9 3/4"
59	4	SQ TUBE: 1-1/2" x 1-1/2" x 11 GA, ASTM A500 GR B	2'-9"
60	4	SQ TUBE: 1-1/2" x 1-1/2" x 11 GA, ASTM A500 GR B	2'-6"
61	2	SQ TUBE: 1-1/2" x 1-1/2" x 11 GA, ASTM A500 GR B	2'-2 1/4"
62	2	SQ TUBE: 1-1/2" x 1-1/2" x 11 GA, ASTM A500 GR B	1'-6 1/4"

QTY-1

(B.O.M. IS FOR A QTY OF 1)

NOTES:

- APPROX WEIGHT: 145 LBS
- WPS 1A-17



QTY-1

(B.O.M. IS FOR A QTY OF 1)

NOTES:

- APPROX WEIGHT: 145 LBS
- WPS 1A-17

BILL OF MATERIAL

ITEM	QTY	DESCRIPTION	LENGTH
54	2	ANGLE: L2" x 2" x 1/4", ASTM A-36, PER DETAIL	2"
63	1	SQ TUBE: 1-1/2" x 1-1/2" x 11 GA, ASTM A500 GR B	9'-9"
64	1	SQ TUBE: 1-1/2" x 1-1/2" x 11 GA, ASTM A500 GR B, PER DETAIL	8'-2"
65	2	SQ TUBE: 1-1/2" x 1-1/2" x 11 GA, ASTM A500 GR B	5'-4 3/8"
66	2	SQ TUBE: 1-1/2" x 1-1/2" x 11 GA, ASTM A500 GR B	4'-9 3/4"
67	2	SQ TUBE: 1-1/2" x 1-1/2" x 11 GA, ASTM A500 GR B, PER DETAIL	2'-6 3/8"
68	4	SQ TUBE: 1-1/2" x 1-1/2" x 11 GA, ASTM A500 GR B	2'-6"
69	2	SQ TUBE: 1-1/2" x 1-1/2" x 11 GA, ASTM A500 GR B, PER DETAIL	2'-4 3/4"
70	2	SQ TUBE: 1-1/2" x 1-1/2" x 11 GA, ASTM A500 GR B	2'-2 1/4"
71	2	SQ TUBE: 1-1/2" x 1-1/2" x 11 GA, ASTM A500 GR B	1'-6 1/4"

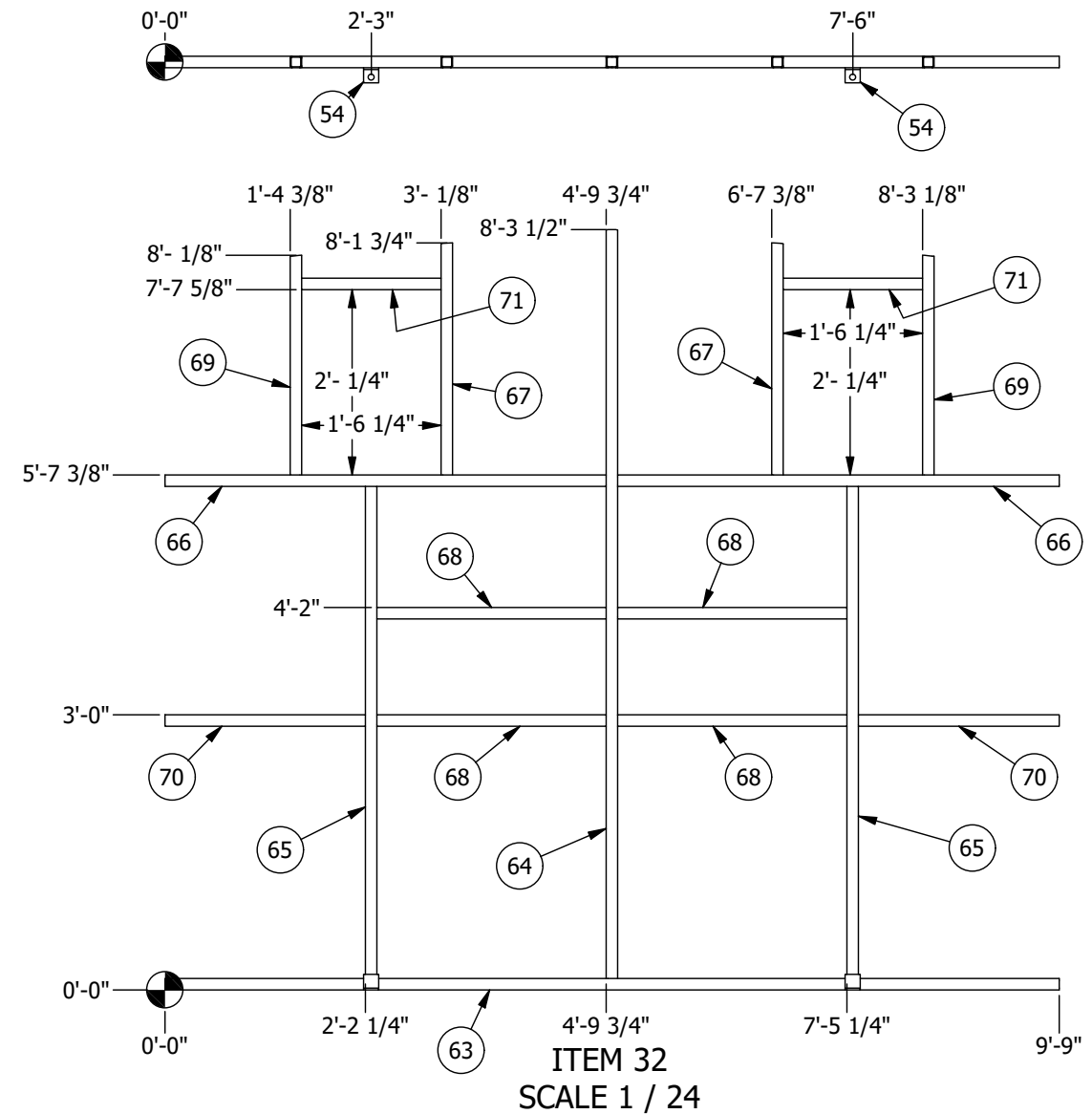
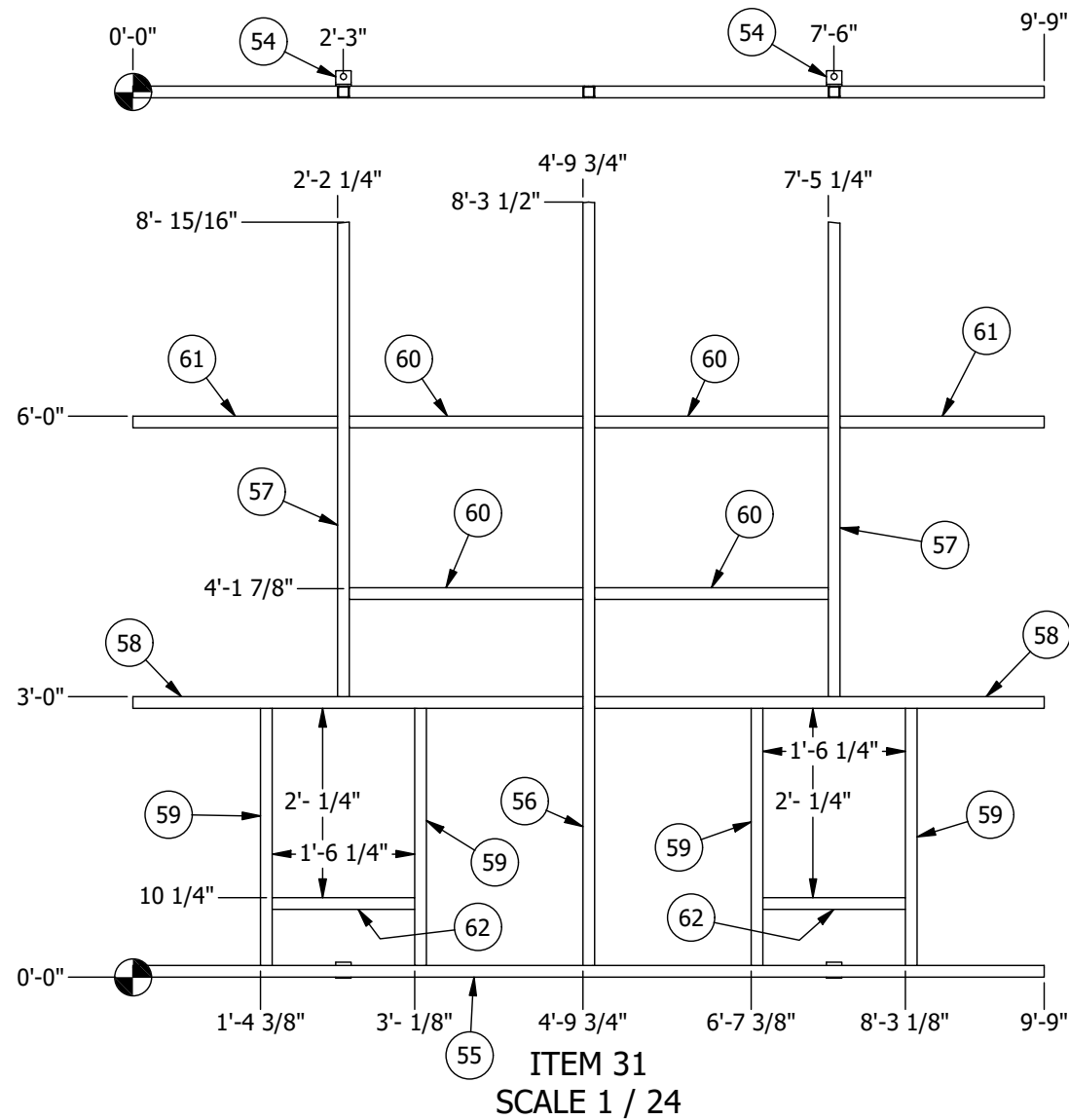

REVISIONS

REV.	DESCRIPTION	BY	DATE
0	ISSUED FOR CONSTRUCTION	EE	4-28-25

GENERAL TOLERANCES:
(UNLESS OTHERWISE SPECIFIED)
SINGLE PART FRACTIONAL: ±1/16"
FABRICATION FRACTIONAL STACK-UP:
0" - 48": ± 1/8"
48" - 96": ± 3/16"
OVER 96": ± 1/4"
ANGLES: ± 1/2°

WELD SIZES ARE MINIMUMS
DEBURR & BREAK SHARP EDGES

THIS DRAWING IS THE PROPERTY OF BLACKEAGLE FABRICATION LLC AND UNLESS GRANTED IN WRITING, DESIGN INFORMATION DISCLOSED WITHIN IS CONFIDENTIAL AND ALL RIGHTS, PATENTS AND OTHERWISE ARE RESERVED BY BLACKEAGLE FABRICATION LLC. DRAWINGS MUST BE SURRENDERED UPON REQUEST.
© ALL RIGHTS RESERVED.



230 COMMERCE DRIVE, BERTHOUD CO, 80513
PHONE: (970) 532-0600 - FAX: (970) 532-4846

BES / XCEL ENERGY

DRAWING APPROVALS

CLIENT	PROJECT MGR.	PROJECT ENG.	QUALITY CONTROL

BAILEY GROUP MS BUILDING SHOP FABRICATION DETAILS

DRAWN DATE:	JOBBOSS #:	DRAWING #:	REV
4/28/2025		225XXX CS-101	0
DRAWN BY:	E. ELLIS	ENGINEER:	

BILL OF MATERIAL			
ITEM	QTY	DESCRIPTION	LENGTH
72	18	SQ TUBE: 1-1/2" x 1-1/2" x 11 GA, ASTM A500 GR B, PER DETAIL	5'- 3/8"
73	12	SQ TUBE: 1-1/2" x 1-1/2" x 11 GA, ASTM A500 GR B	2'-7 1/2"
75	24	ANGLE: L1-1/2" x 1-1/2" x 1/8", ASTM A-36	2'-7 1/2"
74	4	SQ TUBE: 1-1/2" x 1-1/2" x 11 GA, ASTM A500 GR B	2'-7 1/4"
76	8	ANGLE: L1-1/2" x 1-1/2" x 1/8", ASTM A-36	2'-7 1/4"

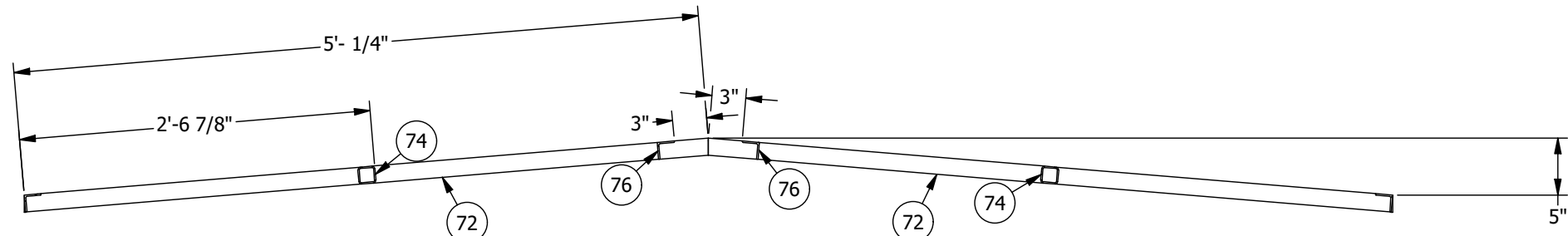

QTY-1
 (B.O.M. IS FOR A QTY OF 1)

NOTES:
 1. APPROX WEIGHT: 387 LBS
 2. WPS 1A-17

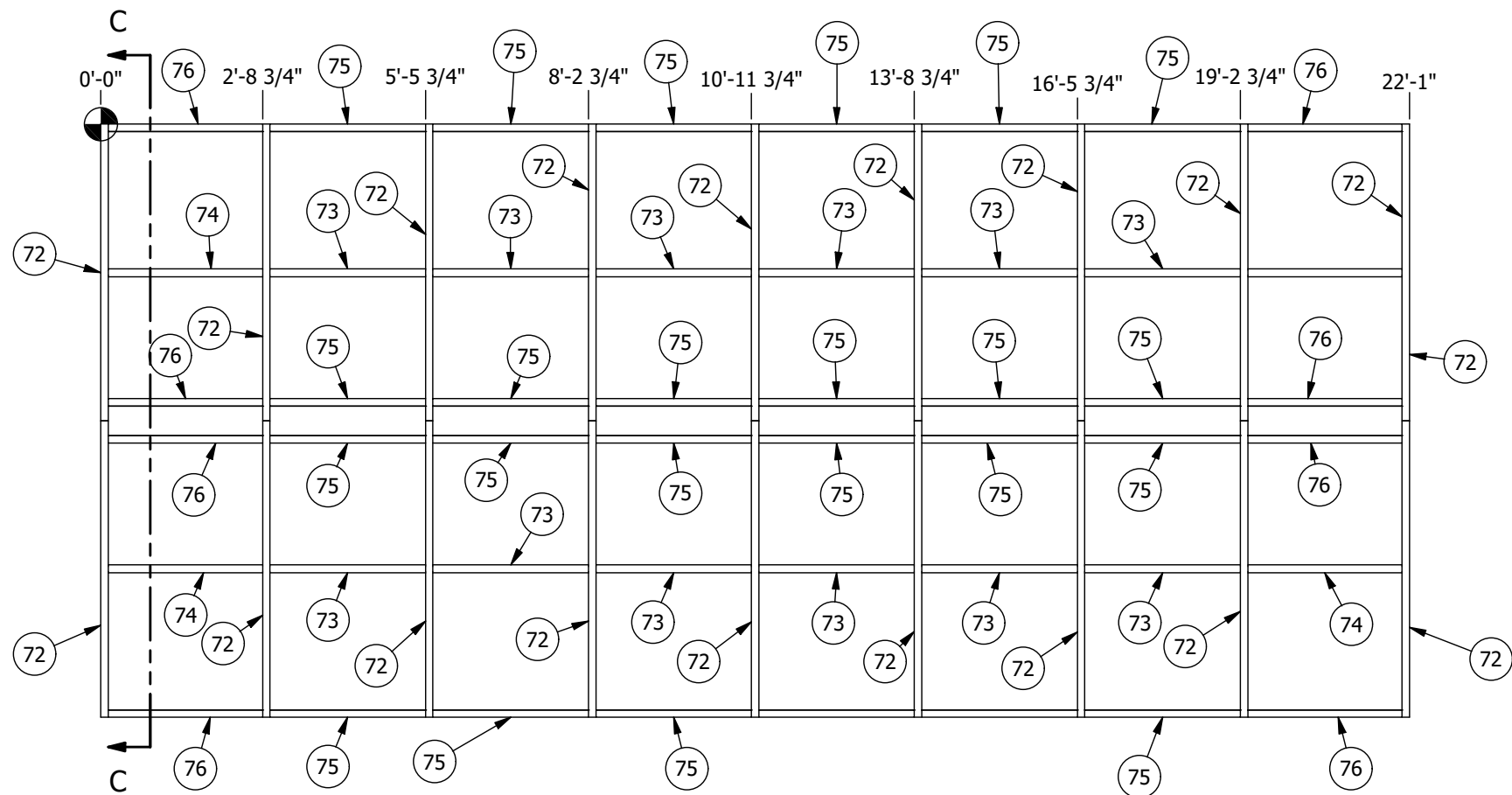

REVISIONS			
REV.	DESCRIPTION	BY	DATE
0	ISSUED FOR CONSTRUCTION	EE	4-28-25

GENERAL TOLERANCES:
 (UNLESS OTHERWISE SPECIFIED)
 SINGLE PART FRACTIONAL: ±1/16"
 FABRICATION FRACTIONAL STACK-UP:
 0" - 48": ± 1/8"
 48" - 96": ± 3/16"
 OVER 96": ± 1/4"
 ANGLES: ± 1/2°

WELD SIZES ARE MINIMUMS
 DEBURR & BREAK SHARP EDGES

THIS DRAWING IS THE PROPERTY OF BLACKEAGLE FABRICATION LLC AND UNLESS GRANTED IN WRITING, DESIGN INFORMATION DISCLOSED WITHIN IS CONFIDENTIAL AND ALL RIGHTS, PATENTS AND OTHERWISE ARE RESERVED BY BLACKEAGLE FABRICATION LLC. DRAWINGS MUST BE SURRENDERED UPON REQUEST.
 © ALL RIGHTS RESERVED.

BLACKEAGLE FABRICATION, LLC



230 COMMERCE DRIVE, BERTHOUD CO, 80513
 PHONE: (970) 532-0600 - FAX: (970) 532-4846

BES / XCEL ENERGY			
DRAWING APPROVALS			
CLIENT	PROJECT MGR.	PROJECT ENG.	QUALITY CONTROL
APPVD BY:			
DATE			

BAILEY GROUP MS BUILDING SHOP FABRICATION DETAILS			
DRAWN DATE: 4/28/2025	JOBBOSS #:	DRAWING #: 225XXX CS-101	REV 0
DRAWN BY: E. ELLIS	ENGINEER:	SHEET 6 OF 6	

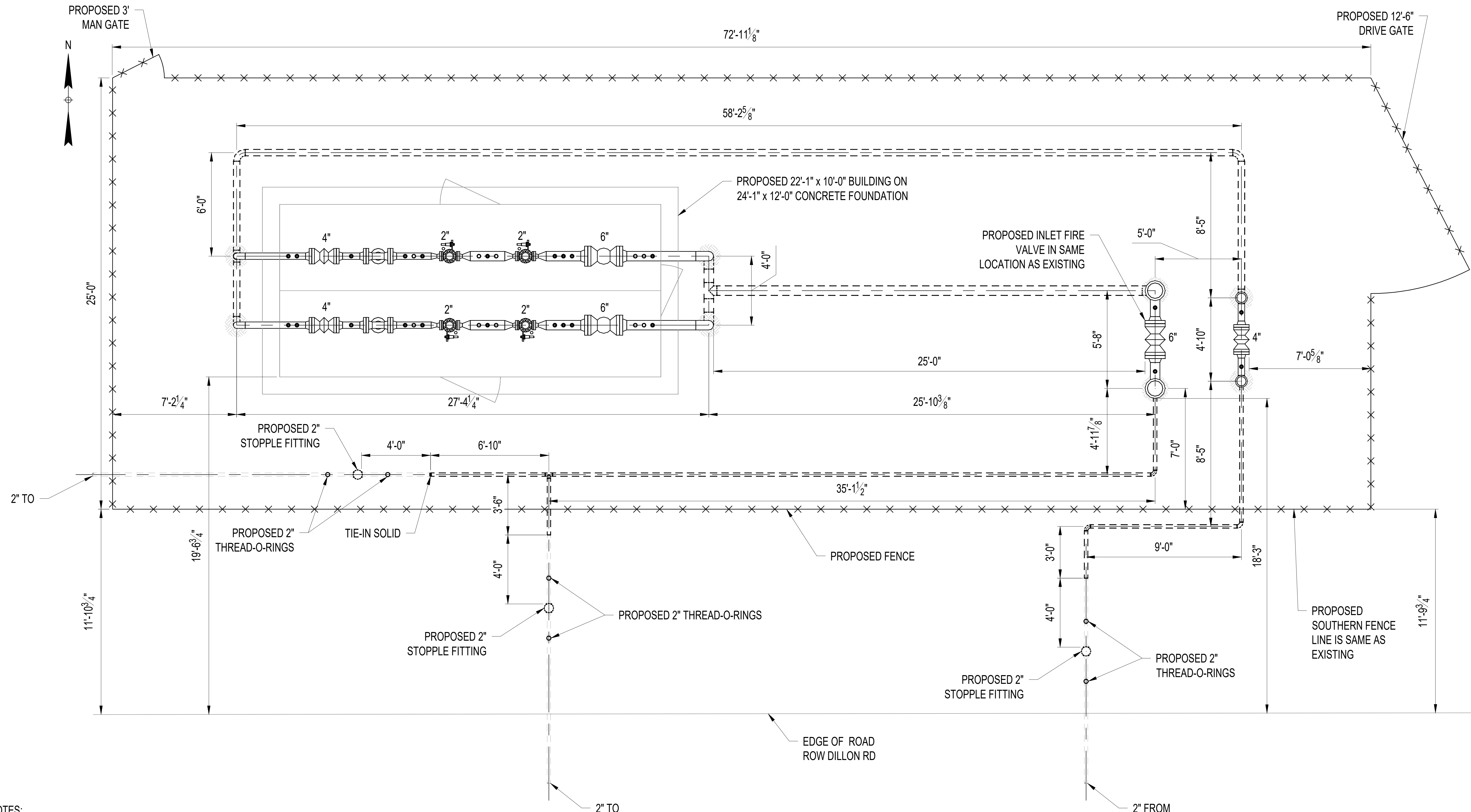

NOTES:
 1) CONTRACTOR IS RESPONSIBLE FOR ALL FIELD VERIFICATION MEASUREMENTS.
 CAD FILE NAME:

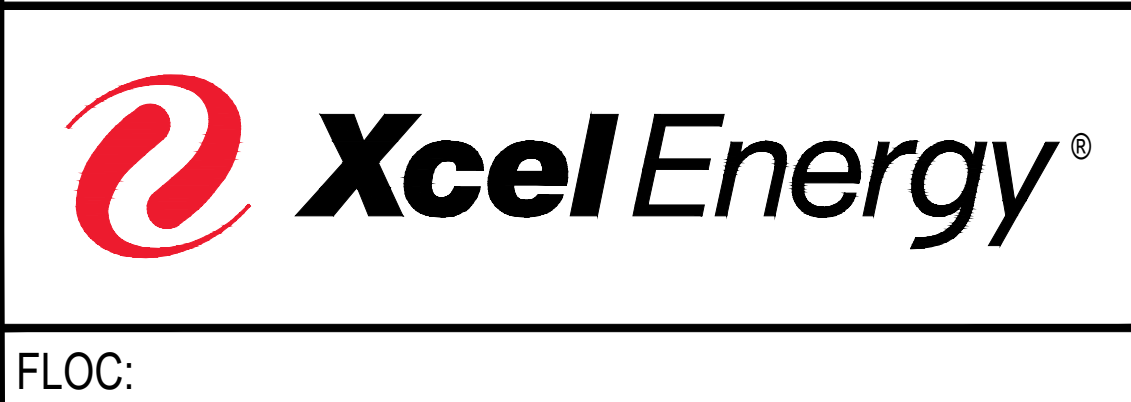

ENEngineering
 9777 PYRAMID COURT, STE 300
 ENGLEWOOD, CO. 80112
 TEL. 303-405-2799
 WWW.ENENGINEERING.COM

HISTORY	DATE
DRAWN BY: BLS	03/10/25
DESIGNED BY: EO	03/05/25
CHECKED BY: JK	03/27/25
APPROVED BY: AC	03/27/25
IN SERVICE DATE:	

REVISIONS			
NO.	DESCRIPTION	BY	DATE
A	ISSUED FOR REVIEW	BLS	03/27/25

Bailey Group MS Rebuild SITE PLAN PIPING	
SERVICE CENTER: BOULDER	LOCATION: S14 T1S R69W
DIVISION: EASTERN	CITY/COUNTY: BROOMFIELD/BOULDER
TYPE: TRANSMISSION	

DRAWING
6100

▲



Community Planning & Permitting

Courthouse Annex • 2045 13th Street • Boulder, Colorado 80302 • Tel: 303.441.3930
Mailing Address: P.O. Box 471 • Boulder, Colorado 80306 • www.bouldercounty.gov

Building Safety & Inspection Services Team

MEMO

TO: Pete L'Orange, Senior Planner
FROM: Michelle Huebner, Plans Examiner Supervisor
DATE: June 30, 2025

RE: Referral Response, VAR-25-0003: Kersting-Motta Setback Reductions: Variance request to reduce the 35-foot front setback to 7 feet and the 110-foot supplemental setback to 28 feet for the construction of a new utility structure.

Location: 11253 Dillion Road

Thank you for the referral. We have the following comments for the applicants:

1. **Building Permit.** A building permit, plan review, and inspection approvals are required for the utility structure. A separate building permit is required for the fence if it's over 6 feet tall.

[2015 Building Code Adoption & Amendments](#)

The Commercial Plan Submittal Checklist: [B70 Commercial Plan Checklist](#)

2. There are several important Building Code requirements that present a potential challenge with this variance request.
3. **The International Building Code (IBC)** restricts openings such as openings in walls, projections (prohibits overhangs), and requires rated assemblies for structures. Please review the IBC and provide a complete code analysis that demonstrate compliance to the code.
4. **Design Wind and Snow Loads.** The design wind and ground snow loads for the property are 140 mph (Vult) and 40 psf, respectively.
5. **Buildings such as this will be reviewed through the International Building Code (IBC) as a commercial building.** A code analysis from a Colorado licensed design professional, an architect, is required.

Claire Levy *County Commissioner* Marta Loachamin *County Commissioner* Ashley Stolzmann *County Commissioner*

6. **2021 International Energy Conservation Code (IECC)** - If the structures, or a portion of them are to be conditioned (heated or cooled), please demonstrate compliance to 2021 IECC – Commercial provisions.
7. **Ignition-Resistant Construction and Defensible Space.** Please refer to Section R390 of the Boulder County Building Code for wildfire hazard mitigation requirements, including ignition-resistant construction and defensible space.
8. **Plan Review.** The items listed above are a general summary of some of the county's building code requirements. A much more detailed plan review will be performed at the time of building permit application, when full details are available for review, to assure that all applicable minimum building codes requirements are to be met. Our Building Safety publications [Building Publications, Applications and Forms - Boulder County](#)

If the applicants should have questions or need additional information, we'd be happy to work with them toward solutions that meet minimum building code requirements. Please call us at (720) 564-2640.



Community Planning & Permitting

Courthouse Annex • 2045 13th Street • Boulder, Colorado 80302
Mailing Address: P.O. Box 471 • Boulder, Colorado 80306
303-441-3930 • www.BoulderCounty.gov

July 14, 2025

TO: Pete L'Orange, Senior Planner; Community Planning & Permitting,
Development Review Team - Zoning

FROM: Tim Oliver, Planner II; Community Planning & Permitting, Development
Review Team – Access & Engineering

SUBJECT: Docket # VAR-25-0003: PSCo Setback Variance at 11253 Dillon Road

The Development Review Team – Access & Engineering staff have reviewed the above referenced docket and have the following comments:

1. The subject property is accessed via Dillon Road, an asphalt Boulder County owned but not maintained right-of-way (ROW) with a Functional Classification of Minor Arterial. Legal access has been demonstrated via adjacency to this public ROW.
2. The Access & Engineering staff have no issues with this proposal.

This concludes our comments at this time.



Parks & Open Space

5201 St. Vrain Road • Longmont, CO 80503
303-678-6200 • POSinfo@bouldercounty.org
www.BoulderCountyOpenSpace.org

TO: Pete L'Orange, Community Planning & Permitting Department
FROM: Ron West, Natural Resource Planner
DATE: July 18, 2025
SUBJECT: Docket VAR-25-0003, Public Service Company, 11253 Dillon Road

Staff has reviewed the submitted materials, and has no natural resource concerns with the requested variance.

From: [Gosselin, Steve](#)
To: [L'Orange, Pete](#)
Cc: [Morgan, Heather](#)
Subject: [EXTERNAL] RE: Referral Packet for VAR-25-0003: PSCo Setback Variance at 11253 Dillon Road
Date: Friday, June 27, 2025 12:41:24 PM

The Fire District has no comments or concerns regarding the proposed setback variance request from the Boulder County Land Use Code for the proposed construction of a roughly 220 square-foot fenced-in utility structure to shelter reconfigured gas valves and associated piping.

Please let me know if you have any questions.

Have a great day!

Steven Gosselin
Division Chief - Fire Prevention
North Metro Fire Rescue District
101 Spader Way
Broomfield, CO 80020
Phone: (303) 252-3540
Fax: (720) 887-8336
E-mail: sgosselin@northmetrofire.org
Website: www.northmetrofire.org



"Excellence Through Each Individual Act."



Be safe. Stay healthy. Stay happy!

From: Morgan, Heather <hmorgan@bouldercounty.gov>
Sent: Friday, June 27, 2025 10:02 AM
To: #AssessorReferral <AssessorReferral@bouldercounty.gov>; #CAreferral <CAreferral@bouldercounty.gov>; Oehlkers, Jason <joehlkers@bouldercounty.gov>; Floodplain Admin <floodplainadmin@bouldercounty.gov>; !LongRange <longrange@bouldercounty.gov>; ReferralsXcelDistribution@xcelenergy.com; planning@lafayetteco.gov; DNR_Area2_Landuse@state.co.us; timothy.bilobran@state.co.us; dora_puc_website@state.co.us; Fire Prevention Shared Mailbox <FirePrevention@northmetrofire.org>; Gosselin, Steve <SGosselin@northmetrofire.org>; bshuler@nwpsy.com; Huebner, Michelle <mhuebner@bouldercounty.gov>; Skufca, Erika <eskufca@bouldercounty.gov>; TD Stormwater Shared Mailbox <stormwater@bouldercounty.gov>; West, Ron <rowest@bouldercounty.gov>; Flax, Ron <rflax@bouldercounty.gov>; Frederick, Summer <sfrederick@bouldercounty.gov>; HealthWaterQuality-EnvironmentalBP LU <HealthWQ-EnvironBPLU@bouldercounty.gov>; Sanchez, Kimberly <ksanchez@bouldercounty.gov>; Transportation Development Review <TransDevReview@bouldercounty.gov>; Duchi, Trevor <tduchi@bouldercounty.gov>
Cc: L'Orange, Pete <plorange@bouldercounty.gov>

Subject: Re: Referral Packet for VAR-25-0003: PSCo Setback Variance at 11253 Dillon Road

My apologies, please see attached for the corrected referral packet for **VAR-25-0003: PSCo Setback Variance** at **11253 Dillon Road**.

Thank you,
Heather Morgan | Lead Administrative Technician
Boulder County Community Planning & Permitting

From: Morgan, Heather
Sent: Friday, June 27, 2025 9:54 AM
Subject: Referral Packet for VAR-25-0003: PSCo Setback Variance at 11253 Dillon Road

Please find attached the referral packet for **VAR-25-0003: PSCo Setback Variance** at **11253 Dillon Road**.

Please return responses and direct any questions to [Pete L'Orange](#) by **July 14, 2025**. (Boulder County internal departments and agencies: Please attach the referral comments in Accela.)

Heather Morgan | Lead Administrative Technician – Planning Division
Boulder County Community Planning & Permitting

P.O. Box 471, Boulder, CO 80306 | Courthouse Annex—2045 13th St., Boulder, CO 80302

hmorgan@bouldercounty.gov | (720) 864-6510 | www.boco.org/cpp

My working hours are Tuesday – Friday from 6:00 a.m. to 4:30 p.m.

From: [Planning Division](#)
To: [L'Orange, Pete](#)
Subject: [EXTERNAL] FW: Referral Packet for VAR-25-0003: PSCo Setback Variance at 11253 Dillon Road
Date: Tuesday, July 8, 2025 2:55:26 PM
Attachments: [image002.png](#)
[image003.png](#)
[image004.png](#)
[image005.png](#)
[image006.png](#)

The City of Lafayette does not have any comments for this referral.

Thank you,
Lauren Fichtner
Administrative Analyst
City of Lafayette | Planning and Building
Office 303-661-1270



From: Morgan, Heather <hmorgan@bouldercounty.gov>
Sent: Friday, June 27, 2025 10:02 AM
To: #AssessorReferral <AssessorReferral@bouldercounty.gov>; #CAreferral <CAreferral@bouldercounty.gov>; Oehlkers, Jason <joehlkers@bouldercounty.gov>; Floodplain Admin <floodplainadmin@bouldercounty.gov>; !LongRange <longrange@bouldercounty.gov>; ReferralsXcelDistribution@xcelenergy.com; Planning Division <planning@lafayetteco.gov>; DNR_Area2_Landuse@state.co.us; timothy.bilobran@state.co.us; dora_puc_website@state.co.us; fireprevention@northmetrofire.org; sgosselin@northmetrofire.org; bshuler@nwpsy.com; Huebner, Michelle <mhuebner@bouldercounty.gov>; Skufca, Erika <eskufca@bouldercounty.gov>; TD Stormwater Shared Mailbox <stormwater@bouldercounty.gov>; West, Ron <rowest@bouldercounty.gov>; Flax, Ron <rflax@bouldercounty.gov>; Frederick, Summer <sfrederick@bouldercounty.gov>; HealthWaterQuality-EnvironmentalBP LU <HealthWQ-EnvironBPLU@bouldercounty.gov>; Sanchez, Kimberly <ksanchez@bouldercounty.gov>; Transportation Development Review <TransDevReview@bouldercounty.gov>; Duchi, Trevor <tduchi@bouldercounty.gov>
Cc: L'Orange, Pete <plorange@bouldercounty.gov>
Subject: Re: Referral Packet for VAR-25-0003: PSCo Setback Variance at 11253 Dillon Road

Warning: Unusual sender <hmorgan@bouldercounty.gov>
You don't usually receive emails from this address. Make sure you trust this sender before taking any actions.

My apologies, please see attached for the corrected referral packet for **VAR-25-0003: PSCo**

Setback Variance at 11253 Dillon Road.

Thank you,
Heather Morgan | Lead Administrative Technician
Boulder County Community Planning & Permitting

From: Morgan, Heather
Sent: Friday, June 27, 2025 9:54 AM
Subject: Referral Packet for VAR-25-0003: PSCo Setback Variance at 11253 Dillon Road

Please find attached the referral packet for **VAR-25-0003: PSCo Setback Variance at 11253 Dillon Road.**

Please return responses and direct any questions to [Pete L'Orange](#) by **July 14, 2025**. (Boulder County internal departments and agencies: Please attach the referral comments in Accela.)

Heather Morgan | Lead Administrative Technician – Planning Division

Boulder County Community Planning & Permitting

P.O. Box 471, Boulder, CO 80306 | Courthouse Annex—2045 13th St., Boulder, CO 80302

hmorgan@bouldercounty.gov | (720) 864-6510 | www.boco.org/cpp

My working hours are Tuesday – Friday from 6:00 a.m. to 4:30 p.m.



Right of Way & Permits

1123 West 3rd Avenue
Denver, Colorado 80223
Telephone: **303.571.3306**
Facsimile: 303.571.3284
Donna.L.George@xcelenergy.com

July 9, 2025

Boulder County Community Planning and Permitting
PO Box 471
Boulder, CO 80306

Attn: Pete L'Orange

Re: PSCo Setback Variance, Case # VAR-25-0003

Public Service Company of Colorado's Right of Way & Permits Referral Desk has **no conflict** with **PSCo Setback Variance**.

Donna George
Right of Way and Permits
Public Service Company of Colorado dba Xcel Energy
Office: 303-571-3306 – Email: donna.l.george@xcelenergy.com